

RELACION TEKNIK
MBI QENDRUESHMERINE
KONSTRUKTIVE

**OBJEKTI: “PROJEKTE MODEL” PER
RINDERTIMIN E SHTEPIVE INDIVIDUALE , ME
KOSTO TE ULET DHE EFIÇENCE ENERGJIE**

Autoriteti Kontraktues: Enti Kombetar i Banesave

KONSTRUKTOR:
ING. ARBEN DERVISHAJ

PERPUNUAN:
ING. ARBANA ZELO
ING. ESMERALDA NOVAKU
ING. AFERDITA BRATI

TIRANE, 10.04.2020

RELACION TEKNIK,
Shtepi banimi 1 katesh me çati 1+1, 2+1 dhe 3+1

1. KODET DHE REFERENCAT

Analiza e kontrollit strukturor per kete objekt eshte bere ne perputhje me **EUROKODET DHE KUSHTET TEKNIKE SHQIPTARE si vijon.**

Eurokod 1. Ngarkesat qe veprojne ne ndertesave

Eurokod 8 & 8.3.Projektimi i ndertesave rezistente ndaj temeteve dhe vlerësimi i objekteve ekzistuese

Eurokod 3 Projektimi i strukturave metalike, ENV 1993.

Eurokod 2 Projektimi i strukturave b/arme, ENV 1992.

Eurokod 7 Projektimi i themeleve

KTP N-2 89 dhe Kushtet Teknike te Projektimit ne fuqi.

Gjithashtu llogaritjet dhe konstruimet i jane referuar edhe kushteve shqiptare te projektimit.

1.1 Pershkrimi i strukturave

Objekte 1 katesh me çati 1+1, 2+1 dhe 3+1

Objektet jane realizuar me konstruksion beton/arme dhe mbulimi me konstruksion metalik.

Themelet e objekteve jane realizuar me pllake b/arme 30cm. Betoni do te perdoret i klases C 12/15 per shtresen e varfer 20cm dhe C 16/20 per pllaken b/arme.

Per strukturen beton/arme do te realizohen kolona me permase (25x25) dhe trare me permase (25x35) dhe (25x40).Betoni i perdorur per kolonat dhe traret do te jete C20/25.

Per strukturen metalike do te vendosen profila kryesore kuti me permase (60x80x2) dhe profila metalike sekondare kuti me permase (30x50x2) dhe (20x30x1.5).

Çeliku per elementet metalik do te jete S 275 sipas normave EN 10025, 10027-1

Mbulimi i çatave do te realizohet me tjegulla.

Per te bere te mundur mbeshtetjen e tjegullave ne cati do te perdoren profila metalike L .

Tegelat e saldimit te jene sipas normave EN 288-2, dhe EN 288-3.

Bazuar ne te gjitha dhenat e mesiperme eshte realizuar hedhja e strukturave per llogaritje ne programin Robot Millenium. Mbas hedhjes ne kompjuter jane marre rezultatet e llogaritjeve dhe mbi bazen e tyre eshte realizuar dimensionimi i elementeve strukturore. Me poshte po japim disa skema dhe rezultate te marra nga llogaritjet.

2. MATERIALI

Ne perputhje me Eurokodet dhe kushtet teknike shqiptare llogaritjet e objektit për kontroll u bë per gjendjen e trete kufitare (SLU).

Materialet te perdorura ne objekt dhe karakteristikat fiziko mekanike te tyre jane si me poshte (bazuar në të dhënat e projektit):

2.1 Betoni

Betoni- Do te perdoret beton i klases C12/15 per shtresen e varfer nen pllake dhe C16/20 per pllaken b/arme 30cm.

- **Betoni – klasa C12/15 per shtresen e varfer nen pllake**

-Per te gjitha elementet struktural prej betoni

Pesha e vetjake

$$\rho=2500 \text{ kg/m}^3$$

Rezistenca kubike ne shtypje e betonit

$$f_{ck,cube} = 150 \text{ daN/cm}^2$$

Rezistenca ne shtypje prizmatike e betonit

$$f_{ck} = 120 \text{ daN/cm}^2$$

Moduli i elasticitetit

$$E_c = 270000 \text{ daN/cm}^2$$

Rezistenca ne terheqje te betonit

$$f_{ctm} = 16 \text{ daN/cm}^2$$

$$f_{ctk 0.05} = 11.2 \text{ daN/cm}^2$$

Rezistenca llogaritese ne shtypje

$$f_{cd} = 80 \text{ daN/cm}^2$$

Shformimi kufitar

$$\epsilon_{cu1}=0.0035$$

Koeficienti i Puasonit(beton me carje)

$$\nu = 0.1$$

Koeficienti i sigurise pjesshme

$$\gamma_c = 1.5$$

Rezistenca llogaritese ne shtypje

$$f_{cd} = 80 \text{ daN/cm}^2$$

- **Betoni – klasa C16/20 per pllaken beton/arme**

Per te gjitha elementet struktural prej betoni,
-Pesha e vetjake:

$$\rho=2500 \text{ kg/m}^3$$

-Rezistenca kubike ne shtypje e betonit:

$$f_{ck,cube} = 200 \text{ daN/cm}^2$$

-Rezistenca ne shtypje prizmatike e betonit:

$$f_{ck} = 160 \text{ daN/cm}^2$$

-Moduli i elasticitetit:

$$E_c = 290000 \text{ daN/cm}^2$$

-Rezistenca ne terheqje te betonit:

$$\begin{aligned} f_{ctm} &= 19 \text{ daN/cm}^2 \\ f_{ctk 0.05} &= 13.3 \text{ daN/cm}^2 \end{aligned}$$

-Rezistenca llogaritese ne shtypje

$$f_{cd} = 106.7 \text{ daN/cm}^2$$

-Shformimi kufitar

$$\varepsilon_{cu1}=0.0035$$

-Koeficienti i Puasonit (beton me carje)

$$\nu = 0.1$$

-Koeficienti i sigurise pjesshme

$$\gamma_c = 1.5$$

- **Betoni per strukturen b/arme (elementet vertikal dhe horizontal) klasa C20/25**

Pesha e vetjake

$$\gamma = 2500 \text{ kg/m}^3$$

Rezistenca kubike ne shtypje e betonit

$$f_{cu} = 250 \text{ daN/cm}^2$$

Rezistenca ne shtypje prizmatike e betonit

$$f_{ck} = 200 \text{ daN/cm}^2$$

Moduli i elasticitetit

$$E_c = 300000 \text{ daN/cm}^2$$

Rezistenca llogaritese

$$f_{cd} = 133.3 \text{ daN/cm}^2$$

$$f_{ctm} = 22.1 \text{ daN/cm}^2$$

$$f_{ctk 0.05} = 15.47 \text{ daN/cm}^2$$

Ku

$$f_{ctm} = 0.3 \times f_{ctk}^{(2/3)}$$

$$f_{ctk 0.05} = 0.7 \times f_{ctm}$$

Koeficienti i Puasonit (beton me carje)

$$\nu = 0.1$$

Koeficienti i sigurise pjesshme

$$\gamma_c = 1.5$$

2.2 Armatura shufra Çeliku

Shufrat e hekurit do te jene te llojit B-500 C kane karakteristikat e meposhtme

Shufrat e hekurit te llojit B 500 C sipas normes europiane EN 10080. Ato kane karakteristikat e meposhtme

Rezistenca ne terheqje

$$f_{tk} \geq 5500 \text{ daN/cm}^2 \text{ Sforcimet pragut te rrjedhshmerise}$$

$$f_{yk} = 5000 \text{ daN Moduli i elasticitetit}$$

$$E_c = 2.000.000 \text{ daN/cm}^2$$

Shformimi karakteristik nen ngarkese maksimale euk = 7.5% k= (ft / fy)k = 1.15
Koeficienti i sigurise se pjesshme

$\gamma_s = 1.15$
Rezistenca e llogaritese
 $f_{yd} = 4347.8 \text{ daN/cm}^2$

2.3 Çeliku per elementet metalik

Çeliku per elementet metalik do te jete S 275 sipas normave EN 10025, 10027-1
Pllakat metalike do te jene çelik S 275

S275 $f_y=2750\text{daN/cm}^2$ per trashesi $\leq 16\text{mm}$

Indikacioni i tipit JR ose JO

Per objektet kemi marre ne konsiderate ngarkesat e perhereshme, te perkohshme, sizmike dhe ngarkesen e eres. Ngarkesat jane marre si me poshte.

3.NGARKESAT LLOGARITese

Ngarkesat qe veprojne ne objektin tone do te merren ne konformitet me kushte te shfrytezimit te objektit dhe perkatesisht

3.1 Ngarkesa te perhereshme

Ngarkesa te perhereshme ne kete projekt, duke perfshire te gjitha shtresat :

$$g_{sh} = 100 \text{ Kg/m}^2$$

3.2 Ngarkesa te perkoheshme

Ngarkesave te perkoheshme ne kete projekt sipas EC 1:

$$p = 100 \text{ Kg/m}^2$$

3.3 Ngarkesa e eres

Ngarkesa e eres eshte marre per shpejtesi ere 30m/s. Llogaritja e ngarkeses se eres eshte bere sipas Eurokodit 1. Eshte marre simulimi i eres per drejtimin X \pm dhe drejtimin Y \pm .

3.4 Ngarkesat sizmike

KOEFICIENTET SIZMIK NE PROJEKT

Ne konstruksionin e modeluar jane marre ne konsiderate koeficientet sizmike.
Karakteristikat e truallit per llog e spektrit te shpejtimeve po i marrim si me poshte:

Shpejtimi maksimal i truallit, ne truall te tipit A

a_g 0,3g

Faktori i kategorizimit te tokes sipas llojit

(lloji C)

S 1,15

Koeficienti i sjelljes se objektit sipas kategorizimit

(Sistem Rame)

q_0 3

Koeficienti sipas shkalles se duktilitetit

(DCM, Mesatare)

K_d 1.0

Koeficienti sipas rregullsise se objektit ne lartesi (i rregullt)

K_r 1.0

Koeficienti sipas shkalles se shkaterimit te objektit

α_u/α_1 1,0

Koeficienti i sjelljes se struktures

$q_0 K_d K_r \alpha_u/\alpha_1$ 3

Sipas KTP per llogaritje kemi marre paraprakisht kategorine e truallit C dhe koeficienti i plasticitetit $\Psi=0,28$.

- *Saktesimi i koeficienteve duhet te behet ne funksion te sheshit te ndertimit ku do te realizohet projekti.*

4. KRITERET E PROJEKTIMIT

4.1 Kombinimi i ngarkesave

Strukturat jane llogaritur dhe kontrolluar per gjendjen kufitare (SLU), gjendjen e lejuar te funksionalitetit (SLS) dhe per gjendjen e lejuar te deformimit (shkaterimit) (SLD).

Ngarkesat jane kombinuar sic jane treguar dhe me poshte, ku IE eshte veprimi Sizmik per gjendjen e lejuar nen egzaminim, G_t eshte vlera karakteristike e veprimit te perkohshem, Q_{1k} vlera karakteristike e veprimit variabel te situates se krijuar prej ngarkesave, Q_{ik} eshte vlera karakteristike e situates variable i; γ_g , γ_p and γ_q jane faktore te sigurise pjesore, ψ_{0i} eshte koeficient kombinimi i cili jep 95% te vleres se aksionit variabel i, ψ_{2i} eshte koeficienti i kombinimit i cili jep vleren e perafert te veprimit te perkohshem variable i. Kombinimet e ngarkesave jane marre ne perputhje me Eurokodin 1, si me poshte:

7

Situata ne projekt	Kombinimi i ngarkesave
SLU	
I perhershëm	$\gamma_g G_k + \gamma_q [Q_{1k} + \sum_i(\psi_{0i} Q_{ik})]$
Sizmik	$IE + G_k + \sum_i(\Psi_{2i} Q_{ik})$
SLS	
Rralle	$G_k + Q_{1k} + \sum_i(\psi_{0i} Q_{ik})$
Frekuent	$G_k + \psi_{11}Q_{1k} + \sum_i(\psi_{2i} Q_{ik})$
Gati permanent	$G_k + \sum_i(\psi_{2i} Q_{ik})$
SLD	
Sizmik	$IE + G_k + \sum_i(\Psi_{0i} Q_{ik})$

Vlerat e koeficienteve te kombinimit jane mare ne konsiderate si me poshte :

$$\begin{aligned} \gamma_g &= 1.4 \quad (\text{ose } 1 \text{ nese kontributi i tij jep me shume siguri}) \\ \gamma_q &= 1.5 \quad (\text{ose } 1 \text{ nese kontributi i tij jep me shume siguri}) \\ \psi_{0i} &= 0.7 \\ \psi_{1i} &= 0.6 \\ \psi_{2i} &= 0.3 / 0.6 / 0.8 \end{aligned}$$

Veprimi sizmik eshte mare ne konsiderate me dy komponentet e saj ortogonale , te cilesuar IE_x dhe IE_y ; ku te dy veprimet respektive te komponenteve perfaqesojne te njejten spekter reagimi dhe plotesojne kombinimin kuadratik (CQC), metode e cila eshte perdorur si kombinim i te dyjave perberesve.

Dy kombinimet e mundeshme jane si vijon

$$\begin{array}{lll} IE_x & "+" & 0,3*IE_y \\ 0,3*IE_x & "+" & IE_y \end{array}$$

Ku shenja “+” ka kuptimin “te kombinohet me “

IE_x jane efektet e forcave ne saje te veprimit te aksionit sizmik pergjate aksit te zgjedhur horizontal x ne strukture

IE_y jane efektet e forcave ne saje te veprimit te te njejtit veprim sizmik pergjate aksit te zgjedhur ortogonal y ne strukture .

Efektet inerciale te ngarkesave sizmike te hedhura do te vleresohen duke mare parasysh dhe masat e lidhura dhe me te gjitha ngarkesat e gravitetit qe shfaqen ne kombinimin qe vijon .

$$G_k + \sum_i(\psi_{Ei} Q_{ik})$$

Ku koeficienti i kombinimit ψ_E mer parasysh propabilitetin e ngarkesave $\psi_{Ei}Q_{ik}$ qe nuk mund te jene prezente pergjate gjithë stuktures ne momentin e veprimit te ngarkese sizmike.

Coefficienti ψ per gli edifici

Azione	ψ_0	ψ_1	ψ_2
Sovraccarichi sugli edifici ¹⁾ :			
categoria A: domestici e residenziali	0,7	0,5	0,3
categoria B: uffici	0,7	0,5	0,3
categoria C: aree di congresso	0,7	0,7	0,6
categoria D: aree di acquisto	0,7	0,7	0,6
categoria E: magazzini	1,0	0,9	0,8
Carichi del traffico negli edifici:			
categoria F: peso del veicolo ≤ 30 kN	0,7	0,7	0,6
categoria G: 30 kN < peso del veicolo ≤ 160 kN	0,7	0,5	0,3
categoria H: tetti	0,0	0,0	0,0
Carichi da neve sugli edifici	0,6 ²⁾	0,2 ²⁾	0,0 ²⁾
Carichi da vento sugli edifici	0,6 ²⁾	0,5 ²⁾	0,0 ²⁾

Vlera minimale e kombinimit te koeficientit ψ_{Ei} te prezantuar per te llogaritur efektin e veprimit sizmik do te jete i kategorizuar sipas shprehjeve te meposhtme

Valori del coefficiente ϕ per il calcolo degli ψ_{Ei}

Tipo di azione variabile	Impiego dei piani		ϕ
Categorie A-C*	piani impiegati indipendentemente	piano superiore	1,0
		altri piani	0,5
Categorie A-C*	alcuni piani con impieghi correlati	piano superiore	1,0
		piani con impieghi correlati	0,8
		altri piani	0,5
Categorie D-E* Archivi			1,0

Mbulimi (Ec1-Cat I) $\psi_{Ei} = \psi_{2i} \times \phi = 0,3 \times 1,0 = 0,30$

Kombinimet e futura ne llogaritje jane per te 3 objektet njelloj te paraqitura me poshte :

1. **1.35 G + 1.5 P**
2. **G + 0.3 P + 1 Ex + 0.3 Ey**
3. **G + 0.3 P + 1 Ey + 0.3 Ex**
4. **1.35 G + 1.5 Wx+**
5. **1.35 G + 1.5 Wx-**
6. **1.35 G + 1.5 Wy+**
7. **1.35 G + 1.5 Wy-**

5. MODELET DHE REZULTATET E ANALIZES

Te tri tipet e vilave jane realizuar me te njejten strukture beton/arme(elemente vertikale dhe horizontale), ashtu si dhe konstruksioni metalik per mbulimin e catise.. Jane vila te tipit nje katesh respektivisht me 1 dhome, 2 dhoma dhe 3 dhoma gjumi. Me poshte po japin rezultatet e marra nga programi llogarites “Robot Millenium”.

5.1 Efekte aksidentale ne perdredhje

Ne menyre qe te mbulohen paqartesisht ne pozicionimin e mases dhe ne nocionin e varacionit hapsinor sizmik, qendra e mases ne llogaritje do te konsiderohet e zhvendosur nga cdo qender e vet e nominuar dhe e lokalizuar sipas cdo drejtimi me nje jashtqendesi aksidentale:

$$e_{ai} = \pm 0.05 L_i$$

ku e_{ai} jashtqendesia aksidentale e masave

L_i permasa e godines perpendikular me drejtimin e veprimit sizmik.

Nese shtangesia laterale dhe masa jane te shperndara ne plan mjaftueshmerisht simetrike, efekti aksidental i perdredhjes mund te llogaritet ose te kihet parasysh duke shumefishuar efektin e veprimit te cdo ngarkese individuale ne cdo element me nje factor δ te dhene nga:

$$\delta = 1 + 0.6 \cdot \frac{x}{L_e}$$

Ku:

x eshte distanca nga elementi i marre ne konsiderate (nga qendra e mases se ndertesave ne plan te matur perpendikular me drejtimin e aksionit sizmik te marre ne konsiderate) .

L_e eshte distanca ndermjet dy elementeve me te larget te ngarkuar, e matur perpendikular me drejtimin e veprimit sizmik te marre ne konsiderate.

Godina jone eshte nje godine simetrike si per sa i perket shperndarjes se shtangesise ashtu edhe per sa i perket shperndarjes se masave. Megjithate ne konsiderate eshte marre edhe nje perdredhje aksidentale dhe perkatesisht:

Per rastin tone kemi :

<u>Per modelin 1+1</u>	$e_{ax} = \pm 0.362 m$	dhe	$e_{ay} = \pm 0.561 m$
<u>Per modelin 2+1</u>	$e_{ax} = \pm 0.507 m$	dhe	$e_{ay} = \pm 0.524 m$
<u>Per modelin 3+1</u>	$e_{ax} = \pm 0.694 m$	dhe	$e_{ay} = \pm 0.533 m$

5.2 Faktori i rendesise sipas ndertesave.

Ndertesat jane kategorizuar ne klasa te ndryshme sipas rendesise, duke u nisur nga konseguencat e nje kolapsi per jeten njerezore dhe per rendesine e tyre ne sigurine publike dhe civile, mbrojtja e menjehershme pergjate nje lekundje sizmike, si dhe pasojat sociale dhe ekonomike te nje kolapsi .

Klasat e rendesise te nje objekti jane te karakterizuar nga nje sere faktoresh te ndryshem γ_i te cilat jane te lidhura me pasojat dhe deshtimet e nje strukture.

Faktori i rendesise $\gamma_i = 1,0$ eshte marre ne konsiderate per te dy seksionet.

5.3 Pershkrimi i analizës.

Per shkak te formes se struktures eshte zgjedhur model 3D nen ngarkesa vertikale dhe veprimin e termetit. Modeli per llogaritje dinamike eshte zgjedhur analize modale me masa te perqendruara ne cdo intersektim (i perqendron vete programi) me ane te spektrit te projektimit.

1. Modeli per vilen 1+1



Figura 1. Modeli ne 3D



Figura 2. Ngarkesa e perhershme G

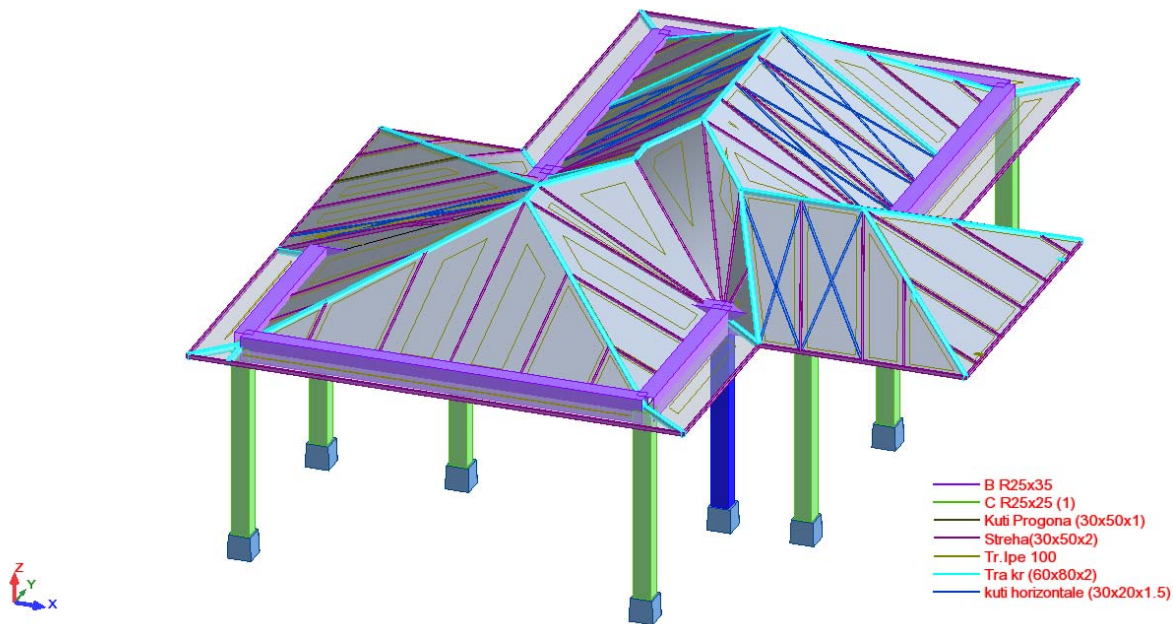

Figura 3. Ngarkesa e perkohshme P

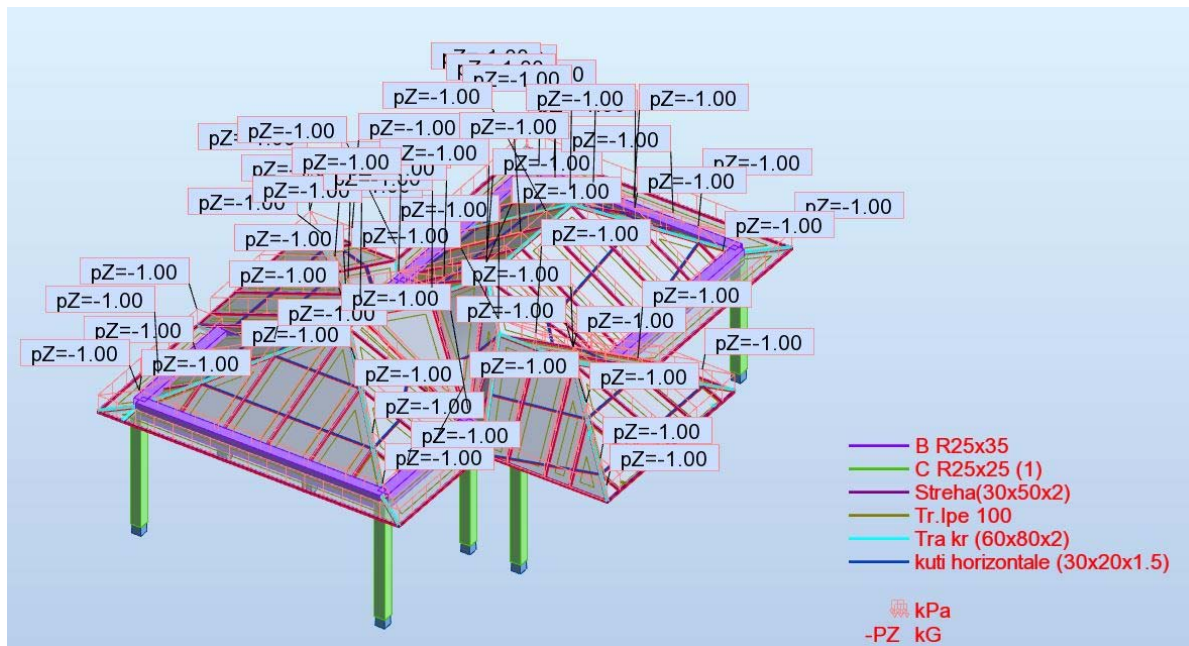

Figura 4. Ngarkesa e eres sipas drejtimit X+ me shpejtesi 30m/s

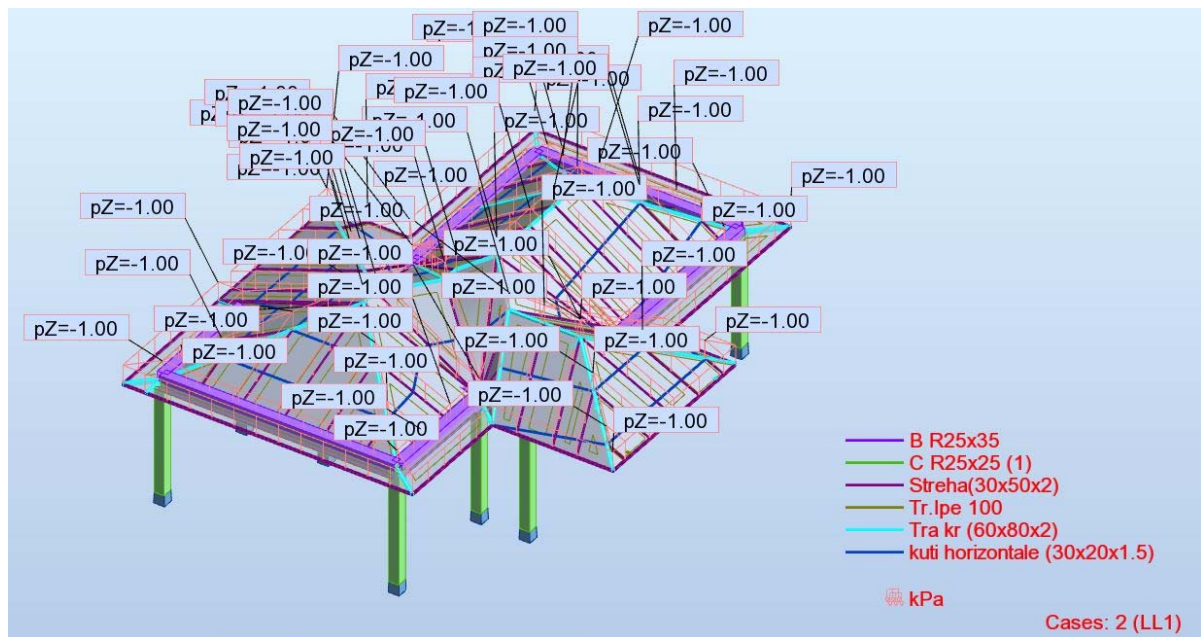

Figura 5. Ngarkesa e eres sipas drejtimit X- me shpejtesi 30m/s

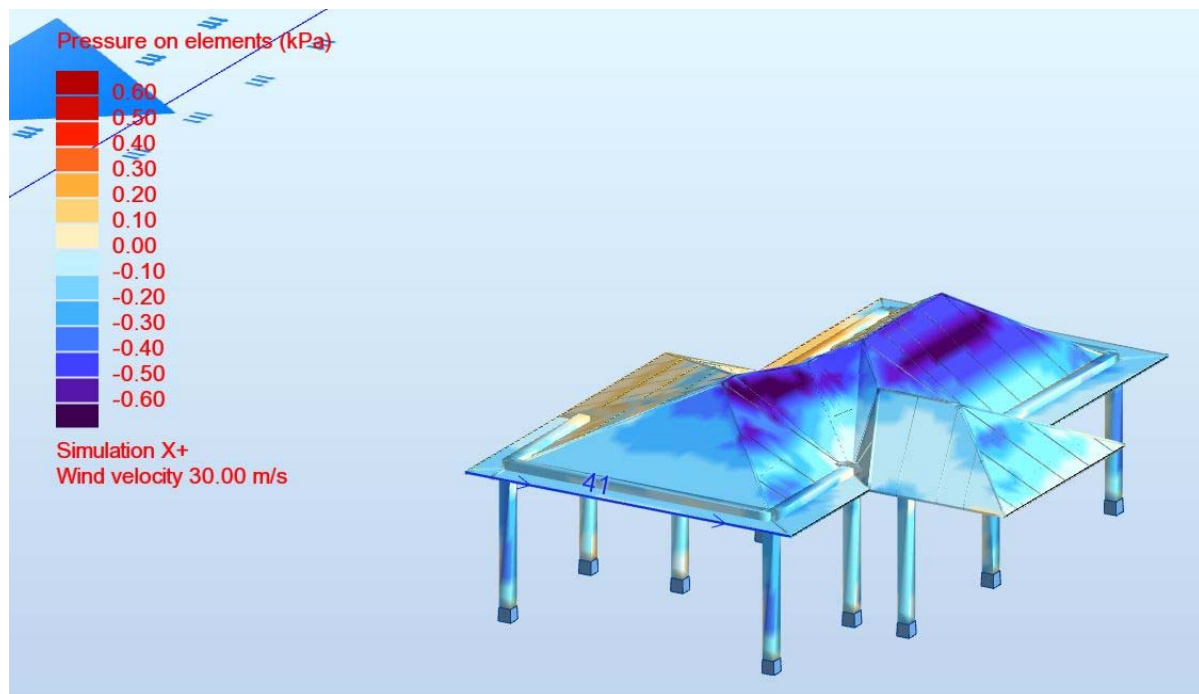

Figura 6. Ngarkesa e eres sipas drejtimit Y+ me shpejtesi 30m/s

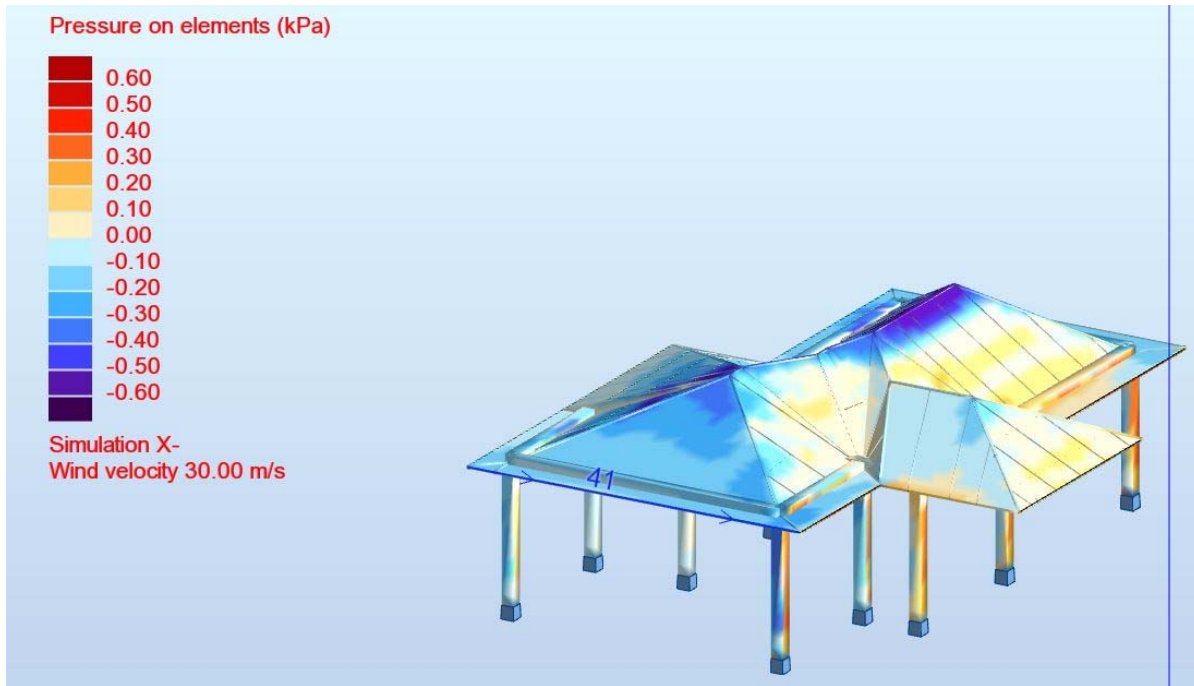

Figura 7. Ngarkesa e erez sipas drejtimet Y me shpejtesi 30 m/s

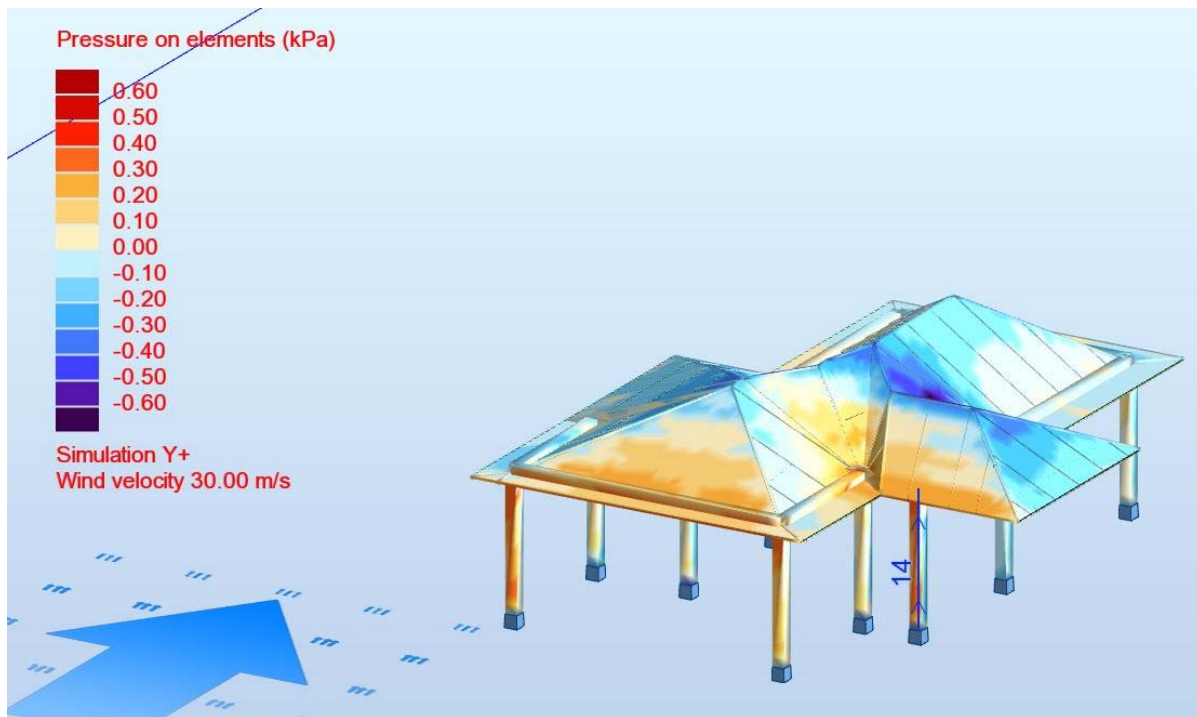

Figura 8. Ngarkesa e sizmikes ag,moduli i sjelljes dhe kategoria e truallit

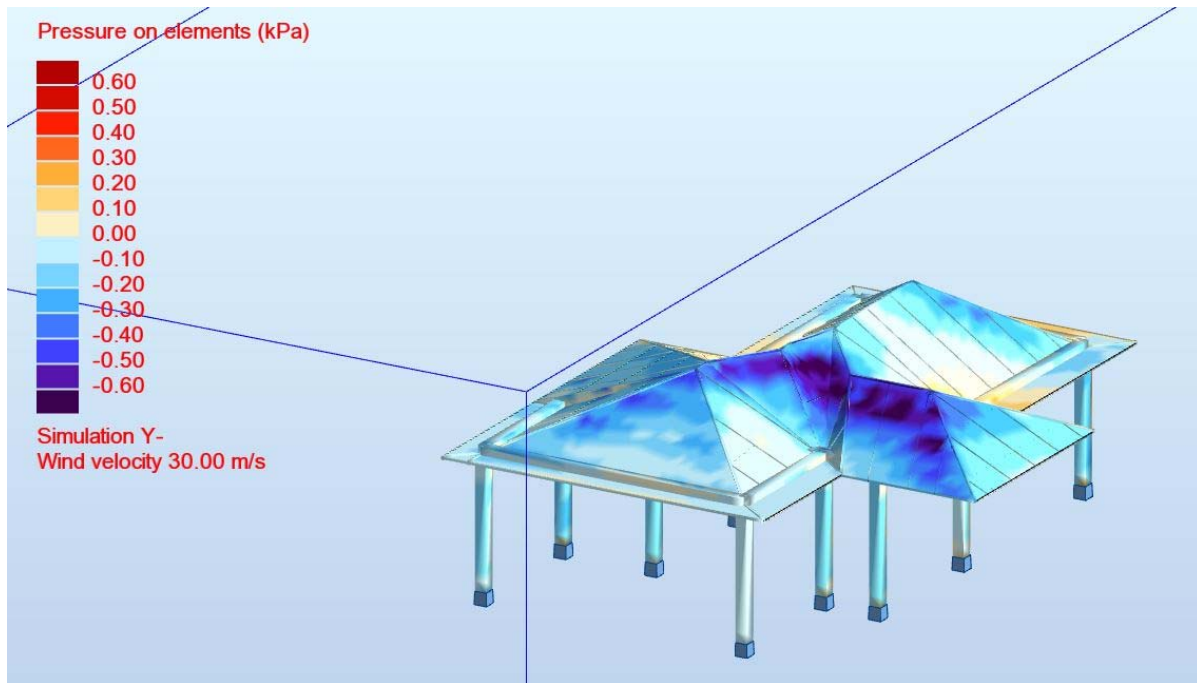

Figura 9. Rezultatet e drifteve nga programi

Perioda baze per seksionin e pare eshte **0.30 sek** qe e fut godinen ne struktura mesatarisht te shtangeta deri pak fleksibel. Kjo periode eshte larg perodes vetiakte te trullit cka shmang fenomenin e rezonances. Vlera e perodes eshte e perafert me ate qe rekomandon Eurokodi 8 per kete kategori strukturash. Sic shihet nga tabela, struktura nuk paraqet problematike per sa i perket fenomenit te perdredhjes. Dy format e para te lekundjes jane levizje translative.

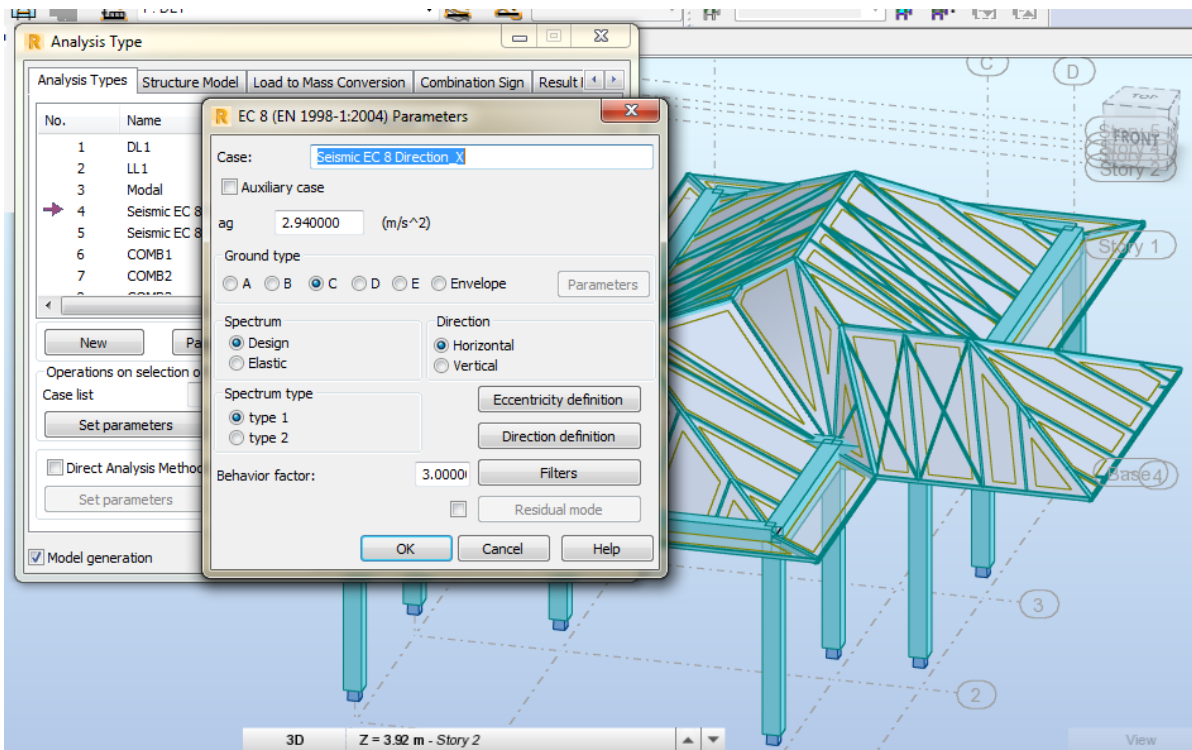
Case/Mode	Frequency (Hz)	Period (sec)	Rel.mas.UX (%)	Rel.mas.UY (%)	Rel.mas.UZ (%)	Cur.mas.UX (%)	Cur.mas.UY (%)	Cur.mas.UZ (%)	Total mass UX (kg)	Total mass UY (kg)	Total mass UZ (kg)
3/ 1	3.32	0.30	0.87	6.58	0.00	0.87	6.58	0.00	38878.94	38878.94	12788.96
3/ 2	3.43	0.29	0.88	7.17	0.00	0.00	0.59	0.00	38878.94	38878.94	12788.96
3/ 3	4.01	0.25	2.30	7.17	0.00	1.42	0.00	0.00	38878.94	38878.94	12788.96
3/ 4	4.04	0.25	3.00	8.67	0.00	0.69	1.50	0.00	38878.94	38878.94	12788.96
3/ 5	4.18	0.24	3.69	9.72	0.00	0.69	1.05	0.00	38878.94	38878.94	12788.96
3/ 6	4.19	0.24	5.42	9.73	0.00	1.74	0.00	0.00	38878.94	38878.94	12788.96
3/ 7	4.47	0.22	38.86	13.98	0.00	33.44	4.26	0.00	38878.94	38878.94	12788.96
3/ 8	5.02	0.20	39.92	21.76	0.00	1.06	7.78	0.00	38878.94	38878.94	12788.96
3/ 9	5.26	0.19	74.09	43.65	0.00	34.17	21.89	0.00	38878.94	38878.94	12788.96
3/ 10	5.41	0.18	79.90	84.16	0.01	5.81	40.51	0.01	38878.94	38878.94	12788.96
4/ 1	3.32	0.30	0.87	6.58	0.00	0.87	6.58	0.00	38878.94	38878.94	12788.96
4/ 2	3.43	0.29	0.88	7.17	0.00	0.00	0.59	0.00	38878.94	38878.94	12788.96
4/ 3	4.01	0.25	2.30	7.17	0.00	1.42	0.00	0.00	38878.94	38878.94	12788.96
4/ 4	4.04	0.25	3.00	8.67	0.00	0.69	1.50	0.00	38878.94	38878.94	12788.96
4/ 5	4.18	0.24	3.69	9.72	0.00	0.69	1.05	0.00	38878.94	38878.94	12788.96

Figura 10. Rezultatet e perodes nga programi

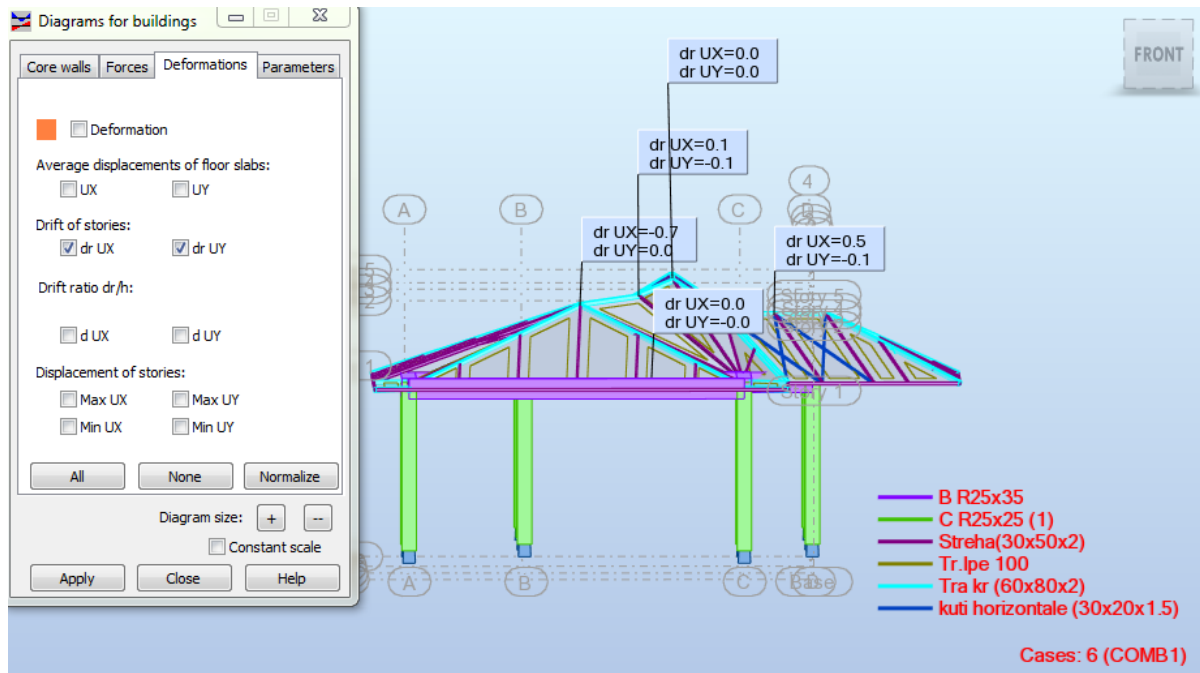
Per sa i perket drifteve qe ka struktura shikojme qe ato jane brenda vlerave qe lejon Eurokodi 8. Per rastin e kontrollit sipas termetit te projektimit duhet qe drifti maksimal i reduktuar me koeficientin v te jete me i vogel se 1 % e lartesis se katit. Nga tabelat e drifteve shihet qe drifti maksimal eshte 0.7 cm.

$$vq_{dr} < 0.005 * 280 = 1.4 \text{ cm}$$

$$0,5 * 0.7 = 0.35 \text{ cm} < 0,005 * 280 = 1.4 \text{ cm}$$

Pra sic shihet kontrolli per limitimin e drifteve eshte i siguruar.

Edhe zhvendosjet maksimale elastoplastike qe rezultojne nga llogaritjet dhe perkatesisht $U_x = 6 \text{ cm}$, $U_y = 4.2 \text{ cm}$, $U_z = 6.5 \text{ cm}$ jane me te vogla se sa limitet qe percakton Eurokodi 8.

	UX (cm)	UY (cm)	UZ (cm)	RX (Rad)	RY (Rad)	RZ (Rad)
MAX	6.0	4.2	6.5	0.093	0.051	0.038
Node	111	280	111	115	109	115
Case	7 (C) (CQC)	8 (C) (CQC)	4	6 (C)	7 (C) (CQC)	7 (C) (CQC)
Mode			CQC			
MIN	-3.1	-2.9	-17.3	-0.094	-0.070	-0.029
Node	83	110	111	102	110	89
Case	6 (C)	6 (C)	6 (C)	6 (C)	6 (C)	6 (C)
Mode						

Figura 11. Rezultatet e zhvendosjeve nga programi

KONTROLI I KAPACITETIT TE ELEMENTEVE

Elementet kryesore te struktures si trare, kollona jane kontrolluar me vete per te analizuar me ne detaje menyren e punes se tyre. Nga programi marrim momentet dhe forcat prerese per traret dhe kollonat si me poshte:

- ❖ Per Traun Tr-04 merren vlerat maksimale per tre kombinimet e ngarkesave te momentit dhe forces presese, per te bere llogaritjen e armatures se nevojshme.



Figura 12. Paraqitja e traut te marre ne analize

- ❖ Rezultatet e momenteve jane si me poshte nga tre kombinimet e ngarkesave dhe maksimalja rezulton per kombinimin 1 :

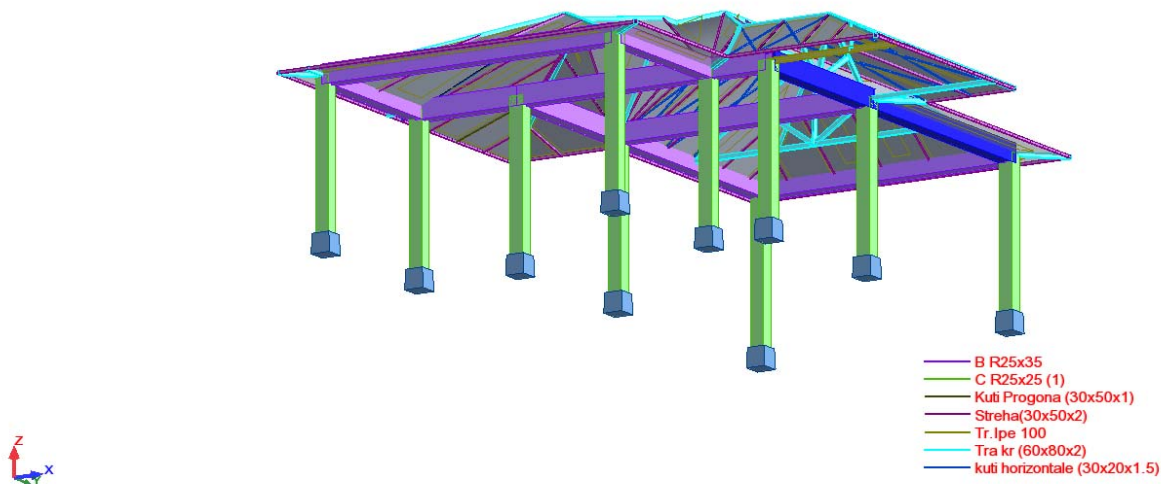
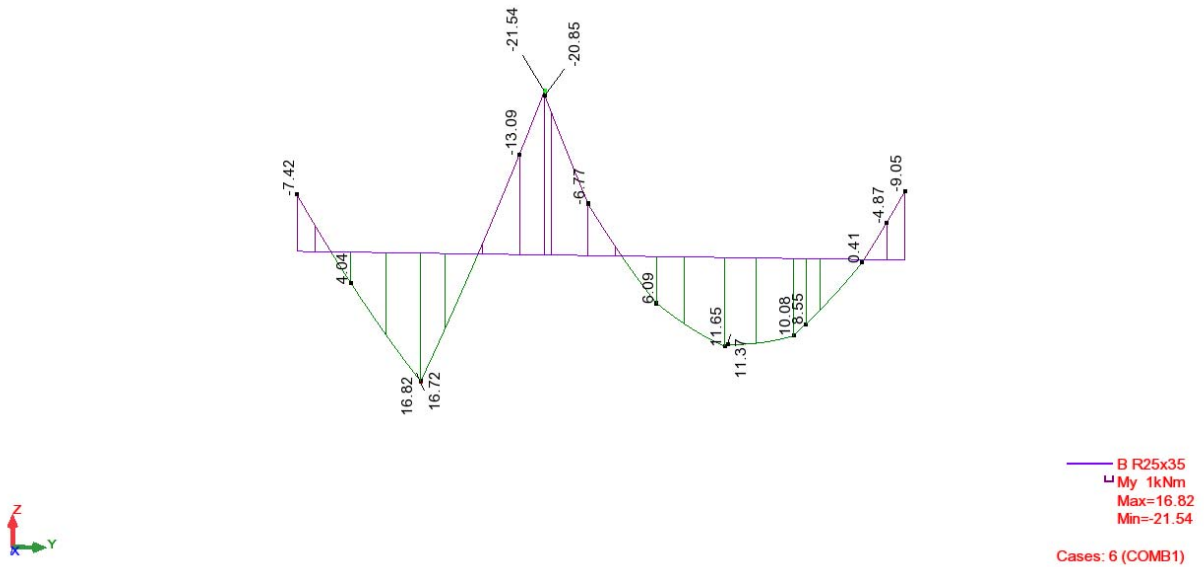

Figure 13. Rezultatet e momenteve maksimale sipas COMB 1

Rezultatet e forcave prerese jane si me poshte nga tre kombinimet dhe maksimalja eshte per kombinimin 1 te ngarkesave:

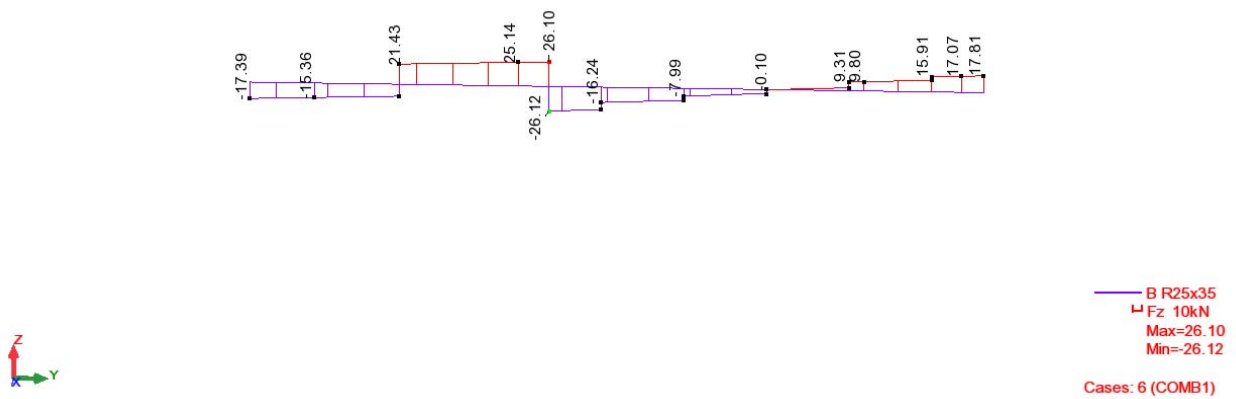

Figure 14. Rezultatet e forcave prerese maksimale sipas COMB 1

Sipas analizes me siper traret jane armuar bazuar mbi kerkesat e minimumit konstruktiv te EC2 dhe EC8 si ne figuren me poshte:

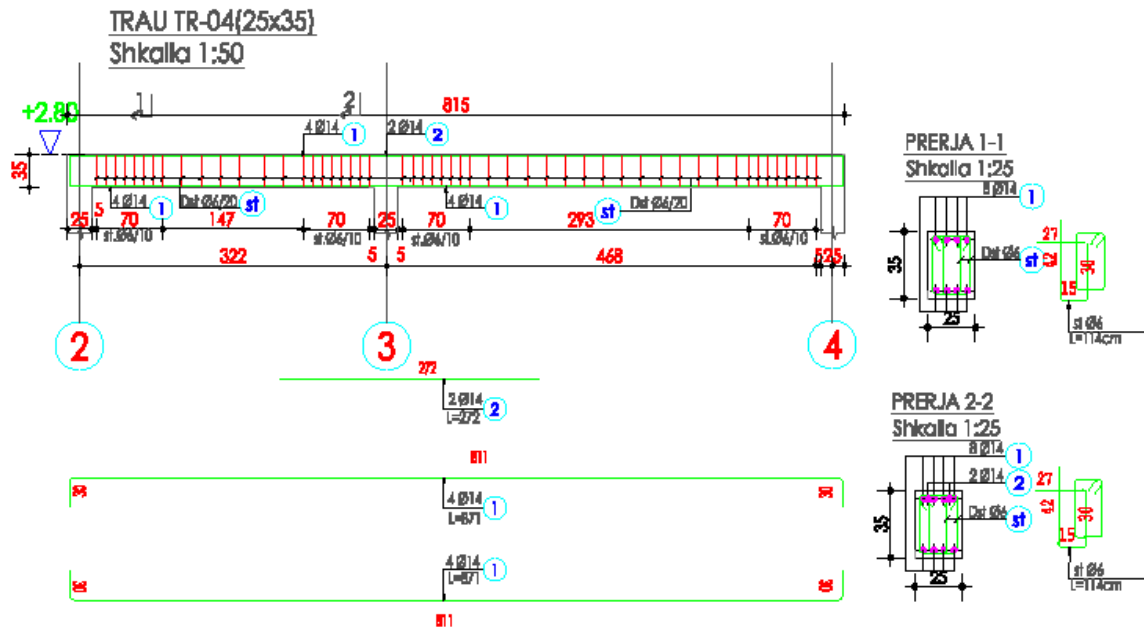

Figure 15. Armimi i traut Tr-04

- ❖ Per te realizuar kontrollin e kollonave te objektit eshte marre ne analize kollona si me poshte dhe eshte paraqitur raporti i plote i llogaritjeve per kete kollone.

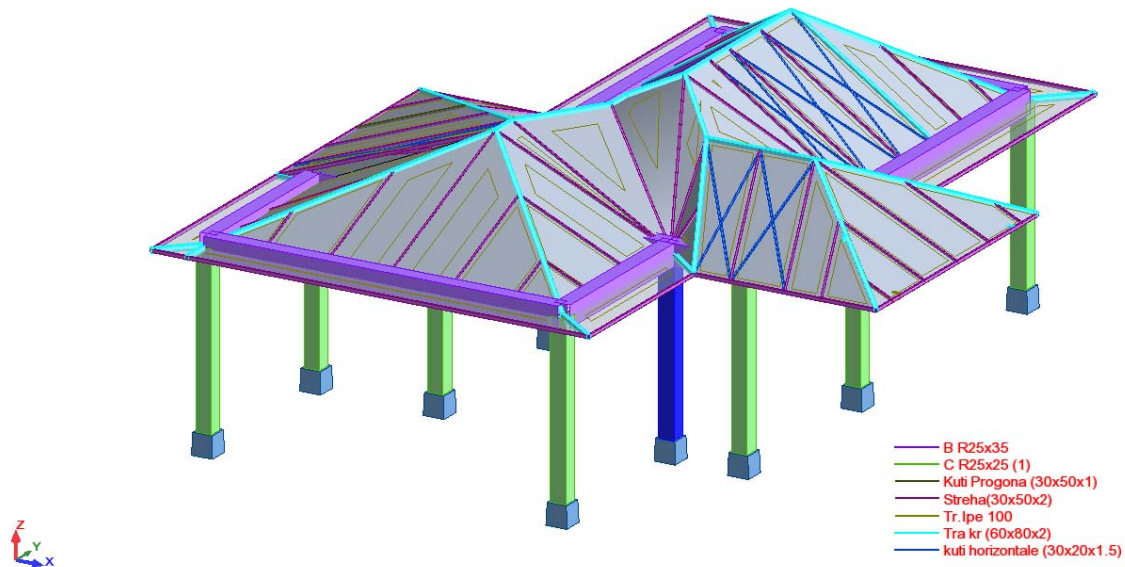

Figure 16. Paraqitja e kollones se marre ne analize

- ❖ Me poshte paraqitet analiza e kollones e nxjerre nga programi:

1 Level:

- Name : :
- Reference level : -0.50 (m)
- Concrete creep coefficient : $\phi_p = 3.26$
- Cement class : N
- Environment class : X0
- Structure class : S1

2 Column: Column9

Number: 1

2.1 Material properties:

- Concrete : C20/25 $f_{ck} = 20.00$ (MPa)
- Unit weight : 2501.36 (kG/m³)
- Aggregate size : 20.0 (mm)
- Longitudinal reinforcement: : B500C $f_{yk} = 500.00$ (MPa)
- Ductility class : C
- Transversal reinforcement: : B500C $f_{yk} = 500.00$ (MPa)

2.2 Geometry:

- 2.2.1 Rectangular 25.0 x 25.0 (cm)
- 2.2.2 Height: L = 2.98 (m)
- 2.2.3 Slab thickness = 0.00 (m)
- 2.2.4 Beam height = 0.35 (m)
- 2.2.5 Cover = 4.0 (cm)

2.3 Calculation options:

- Calculations according to : EN 1992-1-1:2004 AC:2008
- Seismic dispositions : No requirements
- Precast column : no
- Pre-design : no
- Slenderness taken into account : yes
- Compression : with bending
- Ties : to slab
- Fire resistance class : No requirements

2.4 Loads:

Case	Nature	Group	γ_f	N	My(s)	My(i)	Mz(s)	Mz(i)
				(kN)	(kN*m)	(kN*m)	(kN*m)	(kN*m)
COMB1	design(Structural)	9	1.00	17.11	2.97	-2.66	-4.68	4.99
COMB2	design(Structural)	9	1.00	19.75	9.25	-6.89	-7.71	-4.28
COMB3	design(Structural)	9	1.00	20.44	5.98	-3.43	-12.59	-10.03

γ_f - load factor

2.5 Calculation results:

Safety factors $Rd/Ed = 1.95 > 1.0$

2.5.1 ULS/ALS Analysis

Design combination: COMB3 (A)

Combination type: ULS

Internal forces:

$N_{sd} = 20.44$ (kN) $M_{sdy} = 5.98$ (kN*m) $M_{sdz} = -12.59$ (kN*m)

Design forces:

Upper node

$N = 20.44$ (kN) $N^*_{etotz} = 5.98$ (kN*m) $N^*_{etoty} = -12.73$ (kN*m)

Eccentricity: ez (Mv/N) ev (Mz/N)

2.5 Calculation results:

Safety factors $Rd/Ed = 1.95 > 1.0$

2.5.1 ULS/ALS Analysis

Design combination: COMB3 (A)

Combination type: ULS

Internal forces:

$N_{sd} = 20.44$ (kN) $M_{sdy} = 5.98$ (kN*m) $M_{sdz} = -12.59$ (kN*m)

Design forces:

Upper node

$N = 20.44$ (kN) $N^*etotz = 5.98$ (kN*m) $N^*etoty = -12.73$ (kN*m)

Eccentricity:	e_z (My/N)	e_y (Mz/N)
Static	eEd: 29.2 (cm)	-61.6 (cm)
Imperfection	e _i : 0.0 (cm)	0.7 (cm)
Initial	e ₀ : 29.2 (cm)	-60.9 (cm)
Minimal	e _{min} : 2.0 (cm)	2.0 (cm)
Total	e _{tot} : 29.2 (cm)	-62.3 (cm)

2.5.1.1. Detailed analysis-Direction Y:

2.5.1.1.1 Slenderness analysis

Non-sway structure

L (m)	Lo (m)	λ	λ_{lim}	
2.80	2.80	38.80	225.33	Short column

2.5.1.1.2 Buckling analysis

$M_A = 5.98$ (kN*m) $M_B = -3.43$ (kN*m)

Case: Cross-section at the column end (Upper node), Slenderness not taken into account

$M_0 = 5.98$ (kN*m)

$e_a = 0.0$ (cm)

$M_a = N^*e_a = 0.00$ (kN*m)

2.5.1.1.2 Buckling analysis

$MA = 5.98 \text{ (kN}^*\text{m)}$ $MB = -3.43 \text{ (kN}^*\text{m)}$
Case: Cross-section at the column end (Upper node), Slenderness not taken into account
 $M0 = 5.98 \text{ (kN}^*\text{m)}$
 $ea = 0.0 \text{ (cm)}$
 $Ma = N^*ea = 0.00 \text{ (kN}^*\text{m)}$
 $MEdmin = 0.41 \text{ (kN}^*\text{m)}$
 $M0Ed = \max(MEdmin, M0 + Ma) = 5.98 \text{ (kN}^*\text{m)}$

2.5.1.2. Detailed analysis-Direction Z:

$MA = -12.59 \text{ (kN}^*\text{m)}$ $MB = -10.03 \text{ (kN}^*\text{m)}$
Case: Cross-section at the column end (Upper node), Slenderness not taken into account
 $M0 = -12.59 \text{ (kN}^*\text{m)}$
 $ea = \theta1^*b/2 = 0.7 \text{ (cm)}$
 $\theta1 = \theta0^* \alpha h^* \alpha m = 0.01$
 $\theta0 = 0.01$
 $\alpha h = 1.00$
 $\alpha m = (0,5(1+1/m))^*0.5 = 1.00$
 $m = 1.00$
 $Ma = N^*ea = 0.14 \text{ (kN}^*\text{m)}$
 $MEdmin = 0.41 \text{ (kN}^*\text{m)}$
 $M0Ed = \max(MEdmin, M0 + Ma) = -12.73 \text{ (kN}^*\text{m)}$

2.5.2 Reinforcement:

Real (provided) area $Asr = 6.16 \text{ (cm}^2\text{)}$
Ratio: $\rho = 0.99 \%$

2.6 Reinforcement:

Main bars (B500C):

- 4 $\phi 14$ = 2.94 (m)

Transversal reinforcement: (B500C):

stirrups: 14 $\phi 6$ $l = 0.78 \text{ (m)}$

2.5.2 Reinforcement:

Real (provided) area
Ratio:

$Asr = 6.16 \text{ (cm}^2\text{)}$
 $\rho = 0.99 \%$

2.6 Reinforcement:

Main bars (B500C):
• 4 $\phi 14$ = 2.94 (m)

Transversal reinforcement: (B500C):
stirrups: 14 $\phi 6$ l = 0.78 (m)

3 Material survey:

- Concrete volume = 0.16 (m3)
- Formwork = 2.63 (m2)
- Steel B500C
 - Total weight = 16.61 (kG)
 - Density = 101.23 (kG/m3)
 - Average diameter = 10.2 (mm)
 - Reinforcement survey:

Diameter	Length (m)	Weight (kG)	Number (No.)	Total weight (kG)
6	0.78	0.17	14	2.42
14	2.94	3.55	4	14.19

Sipas relacionit te mesiperm te marre nga programi rezulton se % e armimit te nevojshem te kollones na del 0.99 %, e cila eshte me e vogel se minimumi i lejuar nga kodi per armaturen gatesore te kollones.

Kollona, bazuar ne rregullat e EC2 do te armohet me minimumin e shufres $\phi 14$, numri I shufrave per faqe do te jete jo me pak se 3shufra dhe distance midis shufrave jo me e madhe se 20cm.

Bazuar ne minimumin konstruktiv per kolonat e objektit 1+1 eshte dhene armimi si me poshte:



Figura 17. Armimi i kolones b/a(25x25)

Me poshte po japim rezultatet te marra nga programi per elementet metalike te mbulimit:

EN 1993-1:2005/A1:2014 - Member Verification (SLS ; ULS) 32to41 48to50 53 54 56 64 66to71 73 75to83 87 92 95 9

Results		Messages					
Member		Section	Material	Lay	Laz	Ratio	Case
423 Beam_423	OK	Streha(30x50x2)	S 275	41.82	62.75	0.01	8 COMB3
432 Beam_432	OK	Tra kr (60x80x2)	S 275	64.69	80.81	0.23	8 COMB3
434 Beam_434	OK	Tra kr (60x80x2)	S 275	162.42	202.88	0.08	8 COMB3
36 Beam_36	OK	Streha(30x50x2)	S 275	259.27	389.05	0.33	7 COMB2
87 Beam_87	OK	Streha(30x50x2)	S 275	53.05	79.61	0.54	7 COMB2
64 Beam_64	OK	Tra kr (60x80x2)	S 275	81.43	101.72	0.34	6 COMB1
66 Beam_66	OK	Streha(30x50x2)	S 275	178.84	268.36	0.11	6 COMB1
67 Beam_67	OK	Streha(30x50x2)	S 275	115.94	173.97	0.09	6 COMB1
68 Beam_68	OK	Streha(30x50x2)	S 275	53.04	79.58	0.13	6 COMB1
69 Beam_69	OK	Streha(30x50x2)	S 275	115.94	173.97	0.18	6 COMB1
70 Beam_70	OK	Streha(30x50x2)	S 275	53.04	79.58	0.13	6 COMB1
97 Beam_97	OK	Streha(30x50x2)	S 275	98.79	148.24	0.53	6 COMB1
98 Beam_98	OK	Streha(30x50x2)	S 275	38.15	57.25	0.16	6 COMB1
99 Beam_99	OK	Streha(30x50x2)	S 275	159.42	239.22	0.18	6 COMB1
100 Beam_100	OK	Streha(30x50x2)	S 275	159.42	239.22	0.21	6 COMB1
101 Beam_101	OK	Tra kr (60x80x2)	S 275	100.23	125.20	0.17	6 COMB1
108 Beam_108	OK	Streha(30x50x2)	S 275	104.17	156.31	0.58	6 COMB1
109 Beam_109	OK	Streha(30x50x2)	S 275	40.23	60.37	0.16	6 COMB1
110 Beam_110	OK	Streha(30x50x2)	S 275	99.24	148.92	0.62	6 COMB1
113 Beam_113	OK	Streha(30x50x2)	S 275	110.27	165.47	0.80	6 COMB1
114 Beam_114	OK	Streha(30x50x2)	S 275	50.44	75.69	0.30	6 COMB1
213 Beam_213	OK	Tra kr (60x80x2)	S 275	144.37	180.34	0.35	6 COMB1
214 Beam_214	OK	Tra kr (60x80x2)	S 275	140.67	175.72	0.43	6 COMB1
215 Beam_215	OK	Tra kr (60x80x2)	S 275	127.35	159.08	0.20	6 COMB1
216 Beam_216	OK	Tra kr (60x80x2)	S 275	123.32	154.05	0.21	6 COMB1
217 Beam_217	OK	Tra kr (60x80x2)	S 275	111.76	139.61	0.67	6 COMB1
218 Beam_218	OK	Tra kr (60x80x2)	S 275	112.63	140.69	0.66	6 COMB1
429 Beam_429	OK	Tra kr (60x80x2)	S 275	37.33	46.63	0.66	6 COMB1
436 Beam_436	OK	Tra kr (60x80x2)	S 275	54.28	67.80	0.06	6 COMB1
437 Beam_437	OK	Tra kr (60x80x2)	S 275	47.53	59.37	0.04	6 COMB1
438 Beam_438	OK	Tra kr (60x80x2)	S 275	50.11	62.60	0.03	6 COMB1

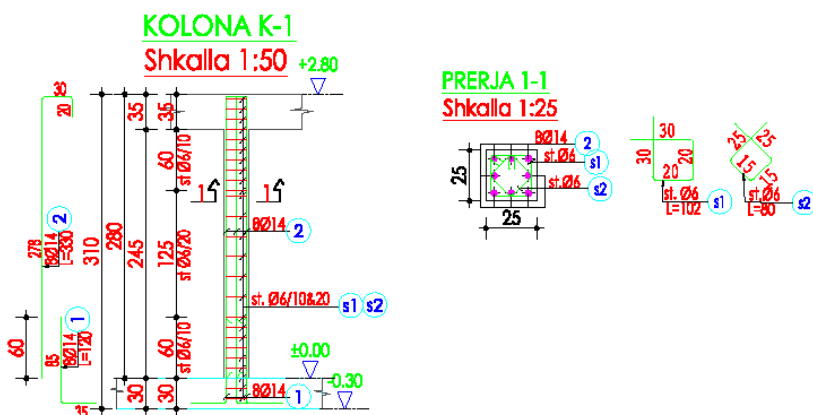
Figure 18. Paraqitja e rezultateve nga analiza e elementeve metalike te mbulimit

KONKLUZIONE

Si perfundim bazuar ne llogaritjet si dhe duke analizuar modelin ne programin Robot Millenium arrijme ne keto konkluzione:

- Ngarkesat e marra ne studim jane ne konformitet me Eurokodet dhe kushtet teknike te projektimit ne fuqi.
- Ngarkesa sizmike eshte marre ne perputhje me Eurokodin 8.
- Perioda e lekundjeve te godines eshte brenda vlerave te rekomanduara nga Eurokodi 8.
- Zhvendosjet dhe driftet e objekteve jane brenda vlerave te lejuara nga Eurokodi 8.
- Armimet e trareve, kollonave dhe themelit jane bere konform kerkesave te Eurokodit 2 & 8.p

Me poshte do te te bashkangjism edhe vizatimet nga projekti :

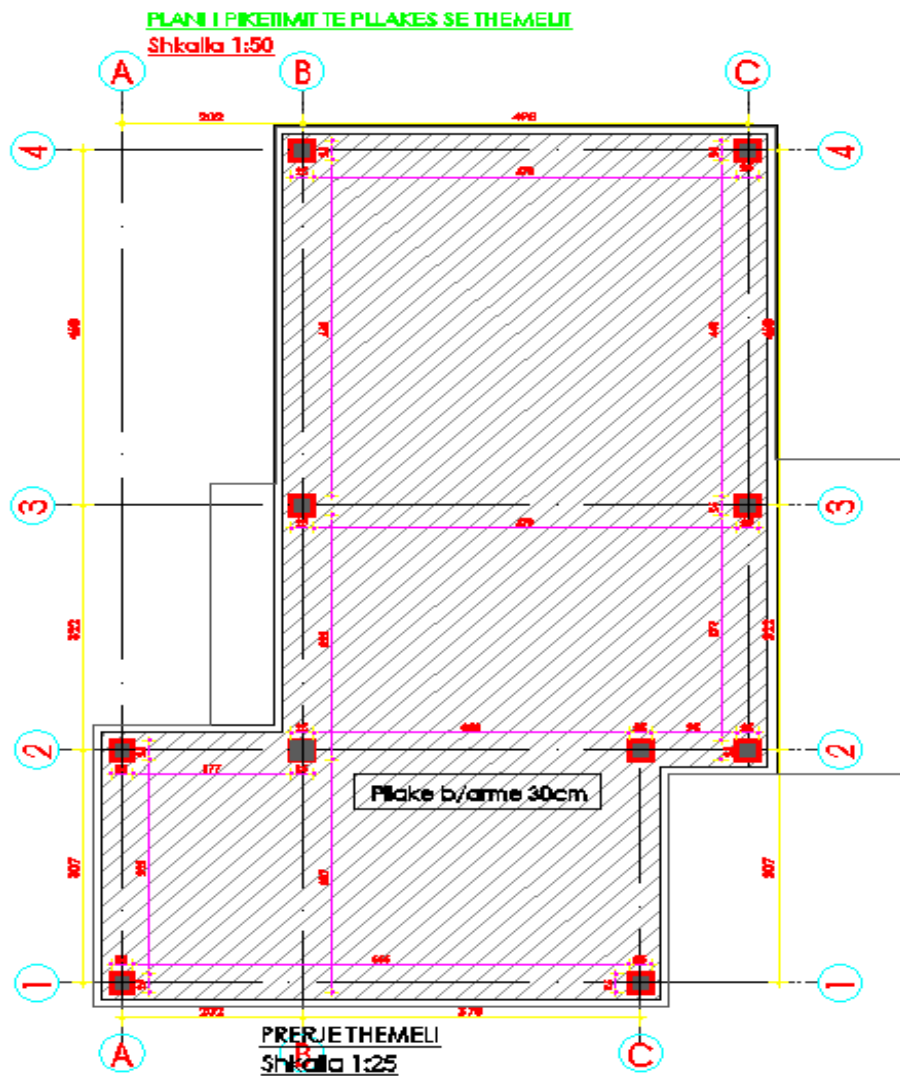

Figure 19. Plani i piketimit te themeleve

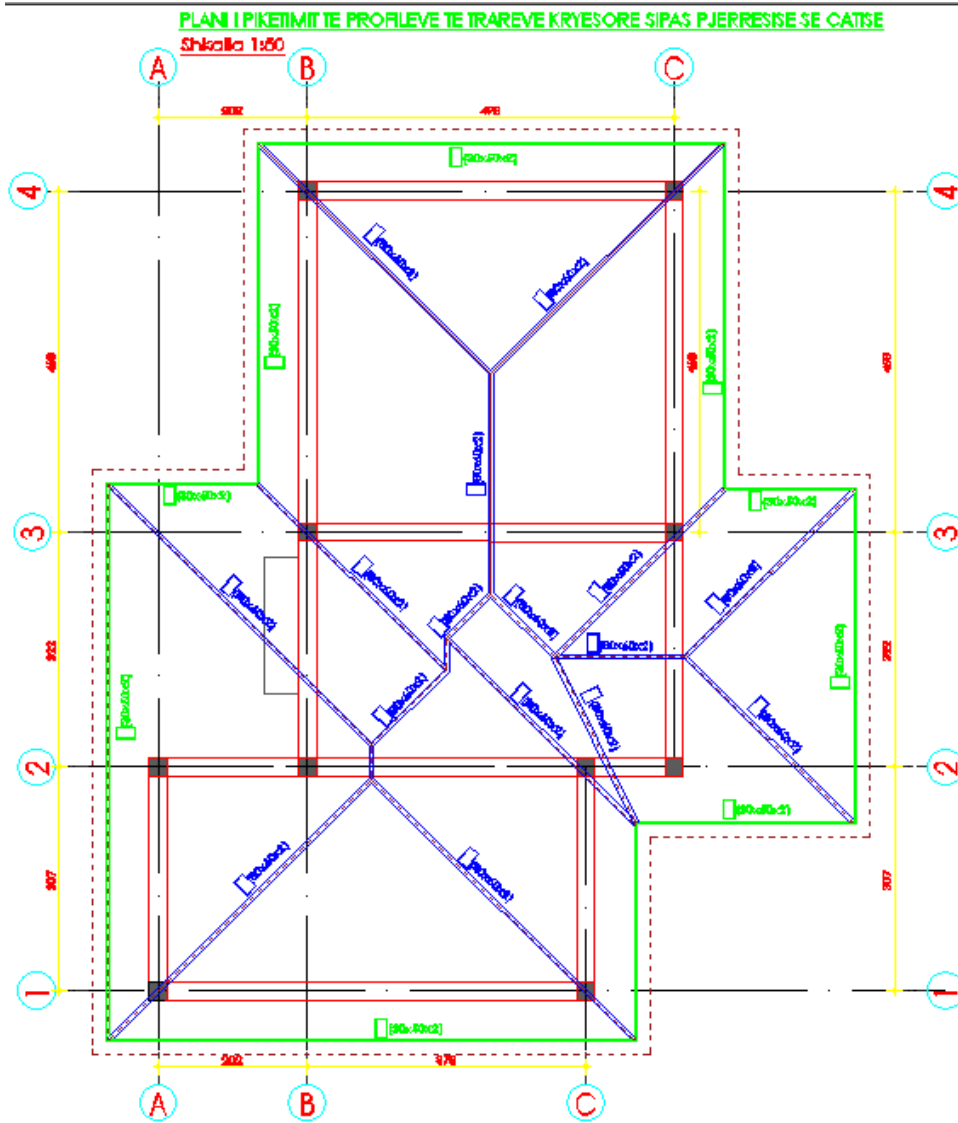

Figure 20. Plani i mbuleses se viles



Figura 3. Ngarkesa e perkohshme P



Figura 4. Ngarkesa e eres sipas drejtimit X⁺ me shpejtesi 30m/s

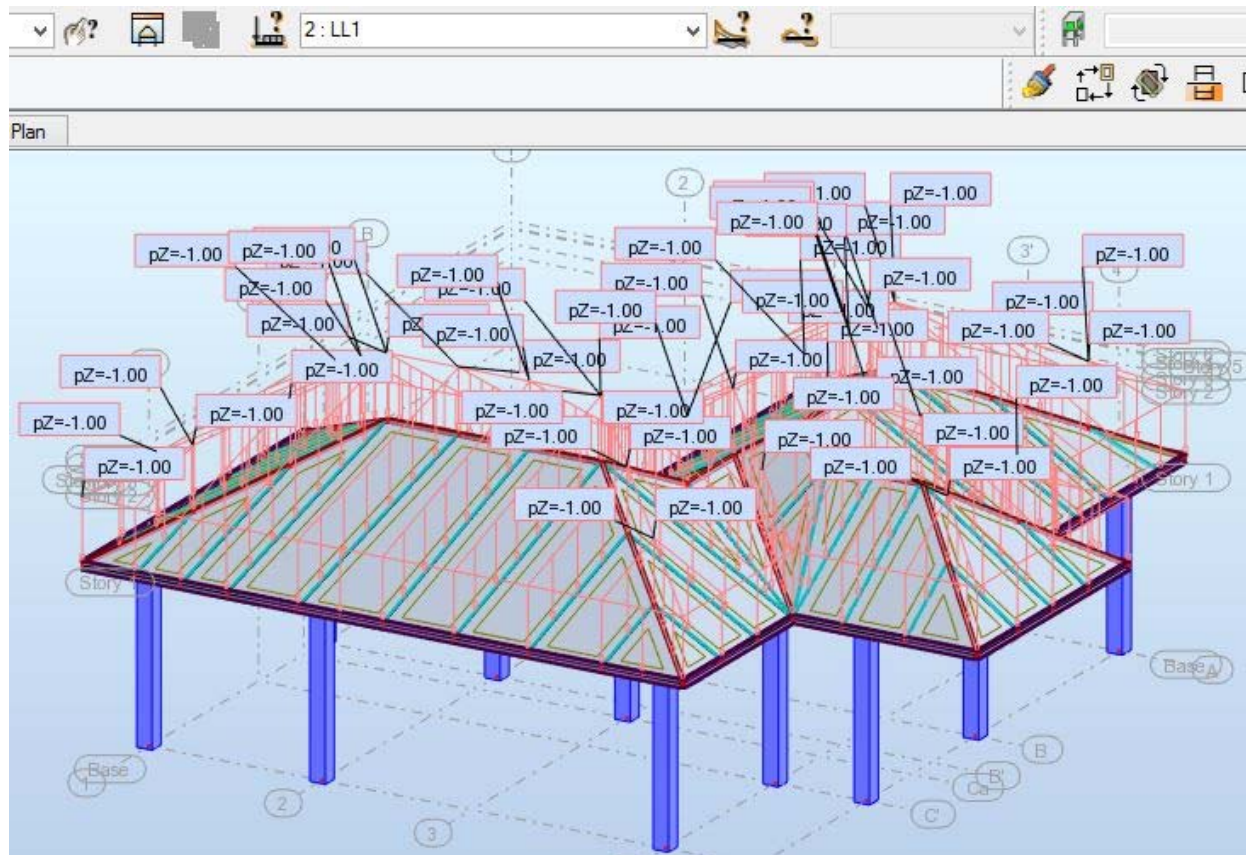

Figura 4. Ngarkesa e eres sipas drejtimit X me shpejtesi 30m/s

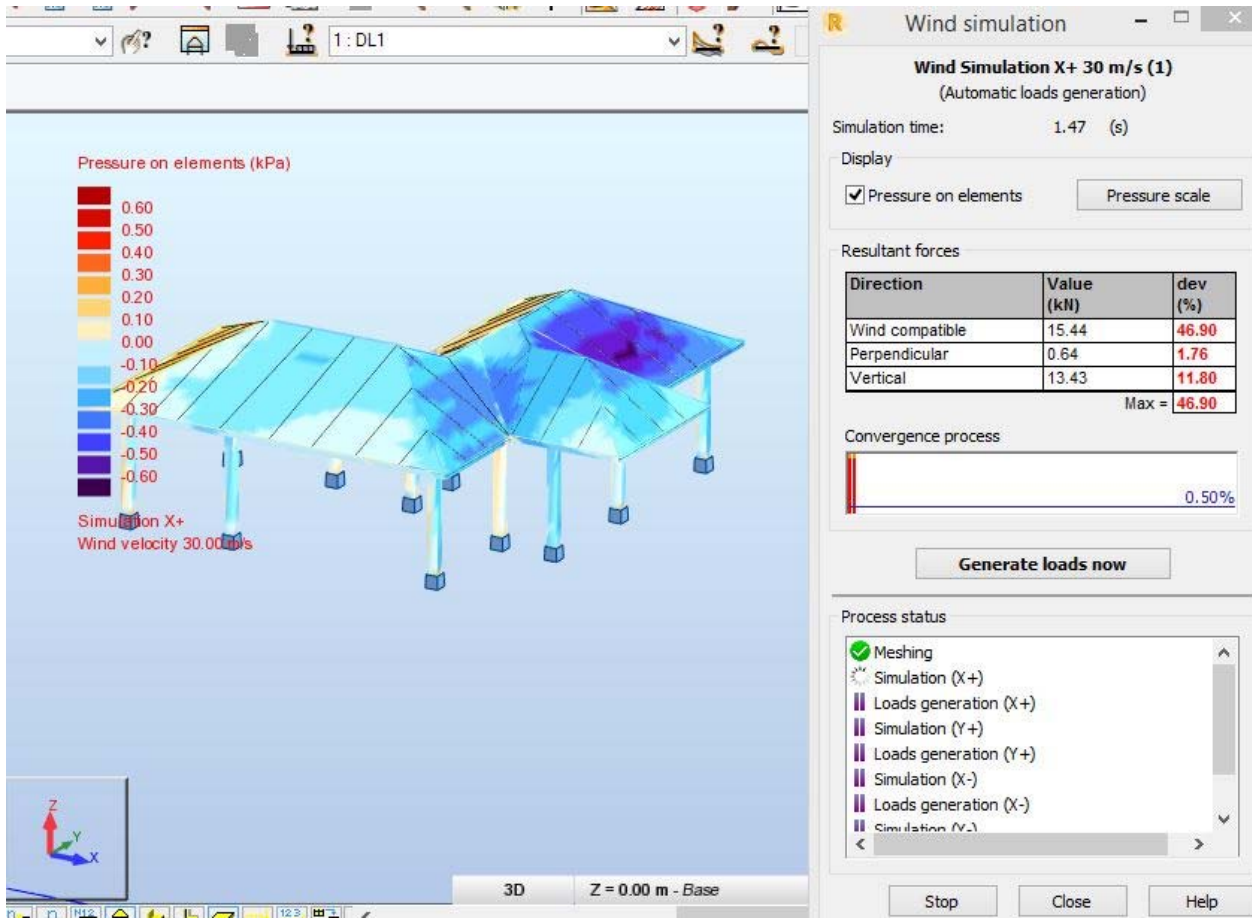

Figura 5. Ngarkesa e eres sipas drejtimit Y⁺ me shpejtesi 30m/s

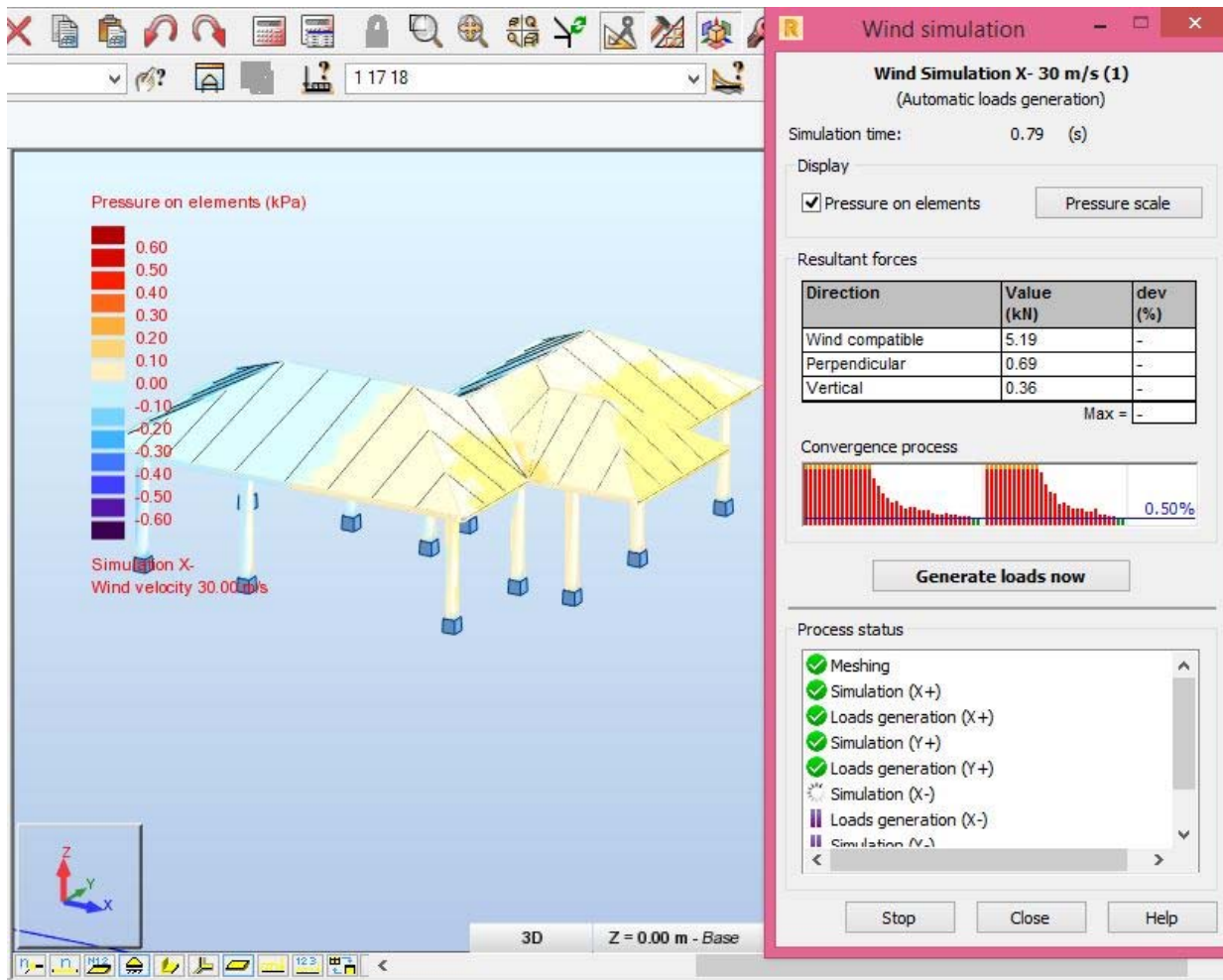

Figura 6. Ngarkesa e eres sipas drejtimit Y me shpejtesi 30m/s

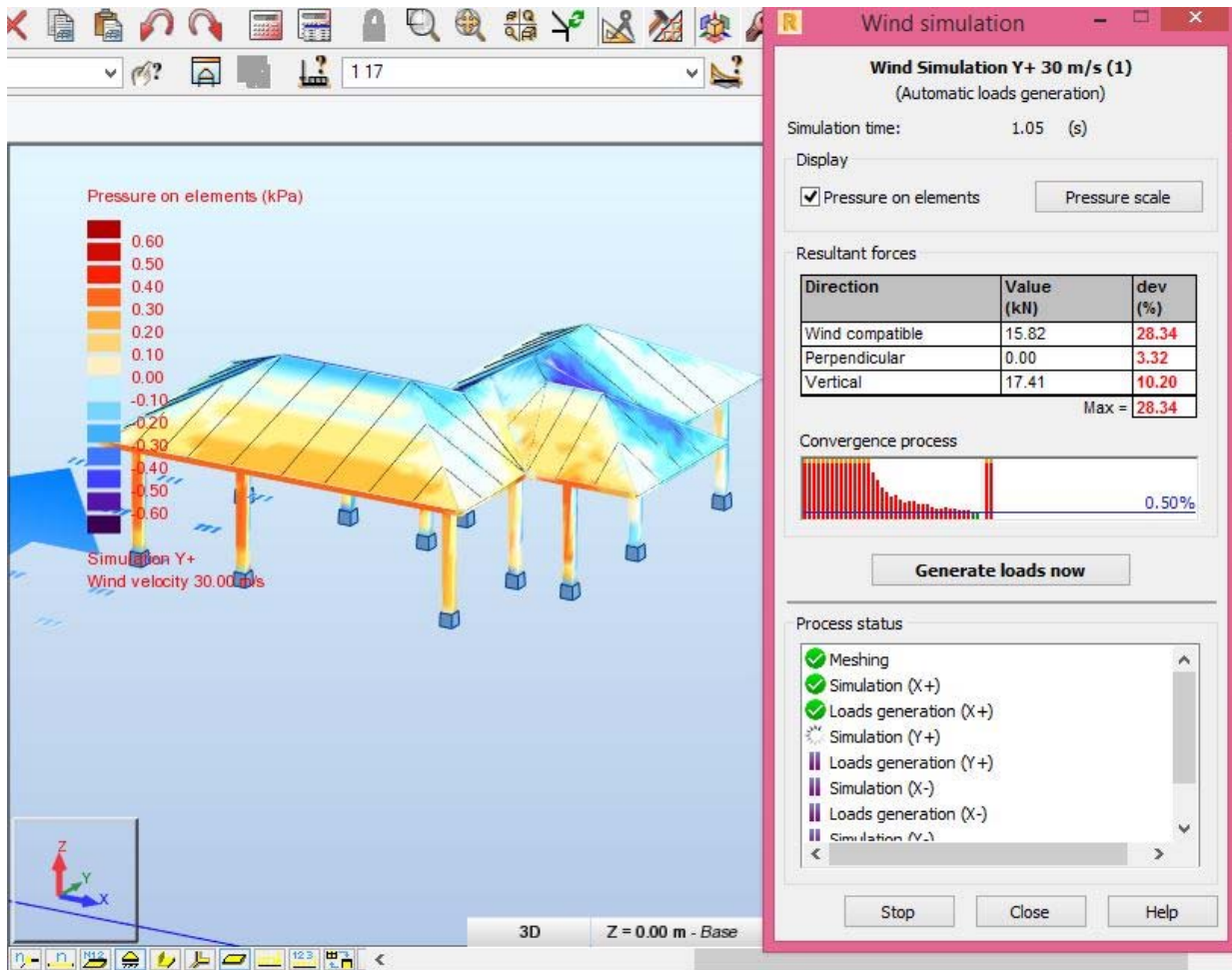

Figura 7. Ngarkesa e sizmikes ag,moduli i sjelljes dhe kategoria e truallit

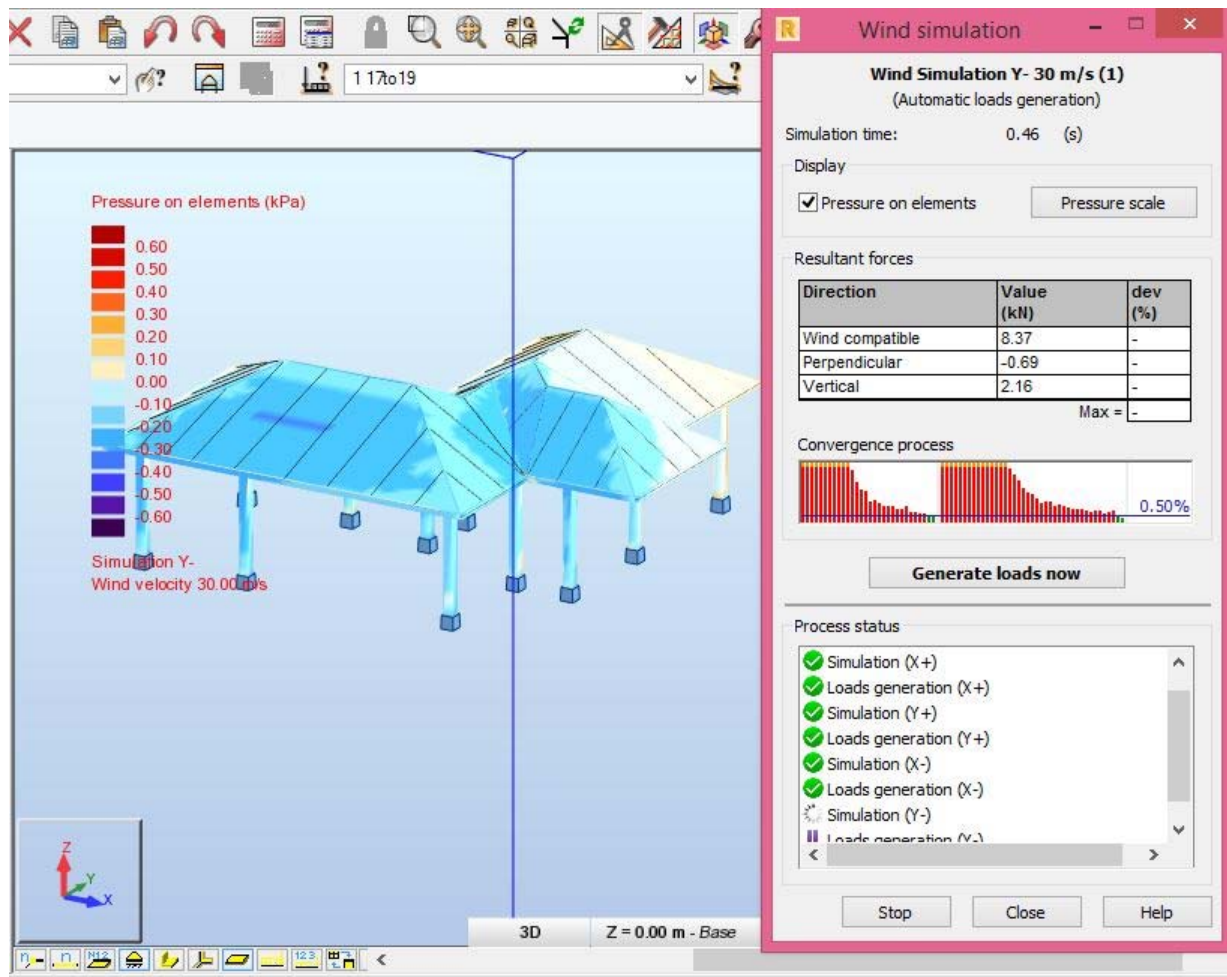

Figura 8. Rezultatet e drifteve nga programi

Perioda baze per seksionin e pare eshte **0.37sek** qe e fut godinen ne struktura mesatarisht te shtangeta deri pak fleksibel. Kjo periode eshte larg perodes vetiakte te truallit cka shmgang fenomenin e rezonances. Vlera e perodes eshte e perafert me ate qe rekomandon Eurokodi 8 per kete kategori strukturash. Sic shihet nga tabela, struktura nuk paraqet problematike per sa i perket fenomenit te perdredhjes. Dy format e para te lekundjes jane levizje translative.

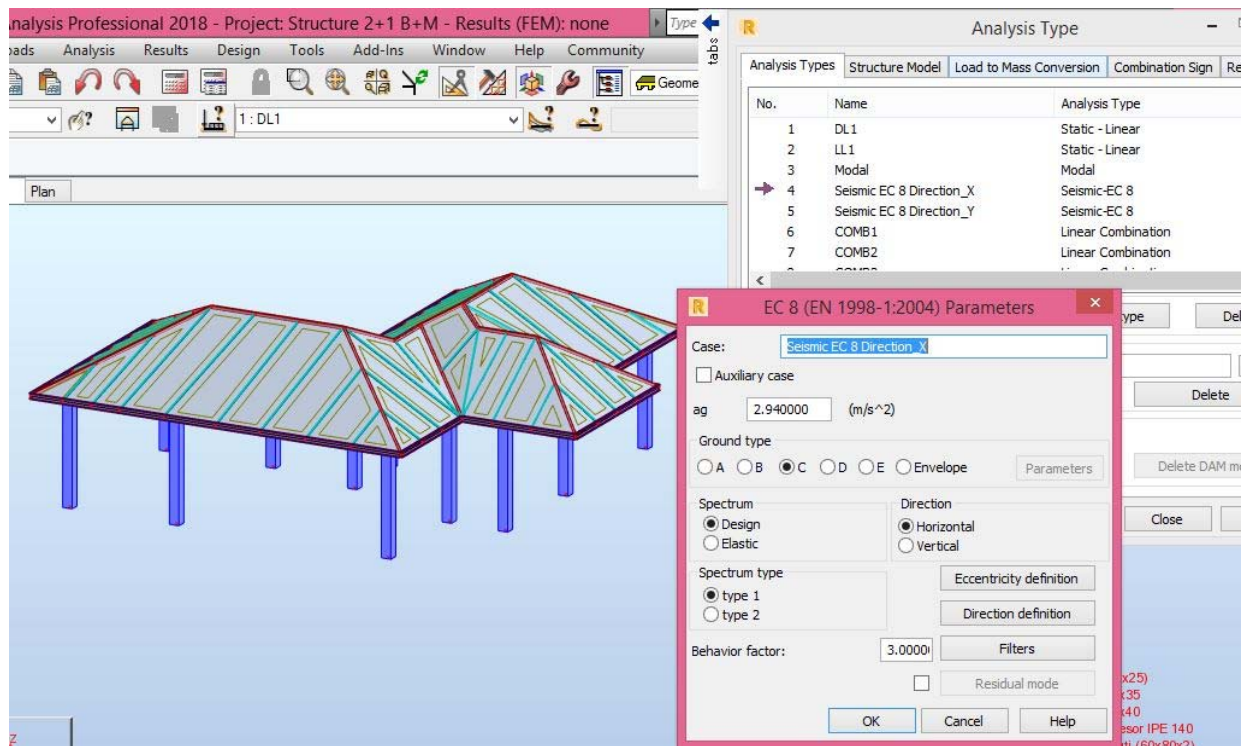
	Frequency (Hz)	Period (sec)	Rel.mas.UX (%)	Rel.mas.UY (%)	Rel.mas.UZ (%)
MAX	8.89	0.37	98.98	98.50	0.0
Case	3	3	3	3	3
Mode	10	1	10	10	1
MIN	2.71	0.11	8.04	0.04	0.0
Case	3	3	3	3	3
Mode	1	10	1	1	1

Figura 9. Rezultatet e perodes nga programi

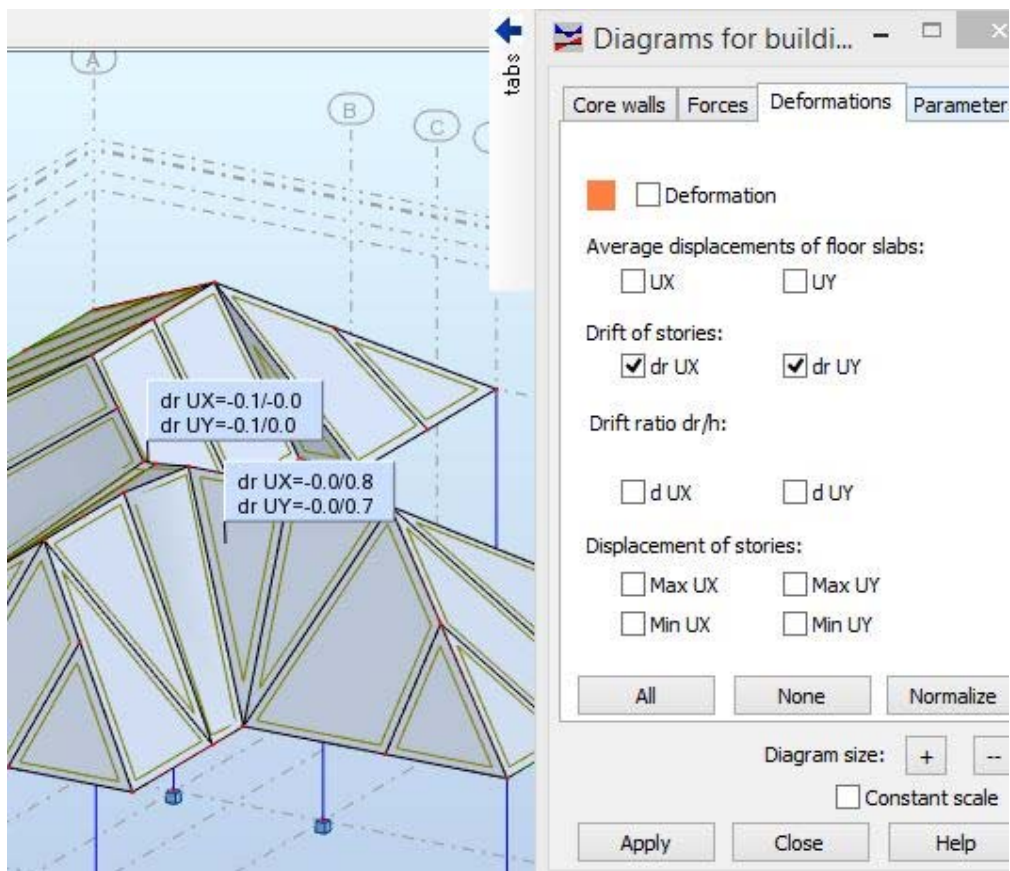
Per sa i perket drifteve qe ka struktura shikojme qe ato jane brenda vlerave qe lejon Eurokodi 8. Per rastin e kontrollit sipas termetit te projektimit duhet qe drifti maksimal i reduktuar me koeficientin v te jete me i vogel se 1 % e lartesis se katit. Nga tabelat e drifteve shihet qe drifti maksimal eshte 0.4 cm.

$$vqdr < 0.005 * 280 = 1.4 \text{ cm}$$

$$0,5 * 0.8 = 0.4 \text{ cm} < 0,005 * 280 = 1.4 \text{ cm}$$

Pra sic shihet kontrolli per limitimin e drifteve eshte i siguruar.

Edhe zhvendosjet maksimale elastoplastike qe rezultojne nga llogaritjet dhe perkatesisht $U_x = 5.4 \text{ cm}$, $U_y = 2.5 \text{ cm}$, $U_z = 5.2 \text{ cm}$ jane me te vogla se sa limitet qe percakton Eurokodi 8.

	UX (cm)	UY (cm)	UZ (cm)	RX (Rad)	RY (Rad)	RZ (Rad)
MAX	5.4	2.5	5.2	0.051	0.040	0.039
Node	52	74	52	76	75	32
Case	7 (C) (CQC)	8 (C) (CQC)	7 (C) (CQC)	7 (C) (CQC)	7 (C) (CQC)	7 (C) (CQC)
MIN	-0.4	-1.6	-6.8	-0.020	-0.034	-0.013
Node	39	37	53	99	89	69
Case	6 (C)	6 (C)	6 (C)	6 (C)	6 (C)	6 (C)

Figura 10. Rezultatet e zhvendosjeve nga programi

KONTROLLI I KAPACITETIT TE ELEMENTEVE

Elementet kryesore te struktures si trare, kollona jane kontrolluar me vete per te analizuar me ne detaje menyren e punes se tyre. Nga programi marrim momentet dhe forcat prerese per traret dhe kollonat si me poshte:

- ❖ Per Traun Tr-08 merren vlerat maksimale per tre kombinimet e ngarkesave te momentit dhe forces prerese, per te bere llogaritjen e armatures se nevojshme.



Figura 11. Paraqitja e traut te marre ne analize

- ❖ Rezultatet e momenteve jane si me poshte nga tre kombinimet e ngarkesave dhe maksimalja rezulton per kombinimin 1 :

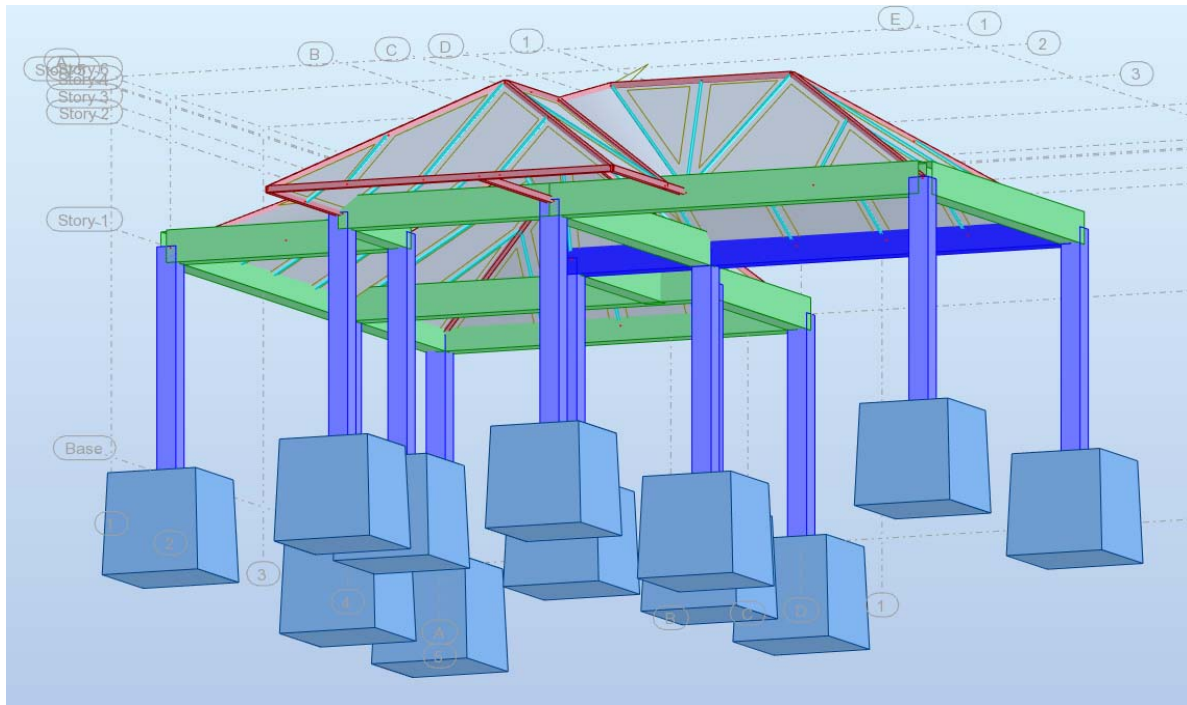
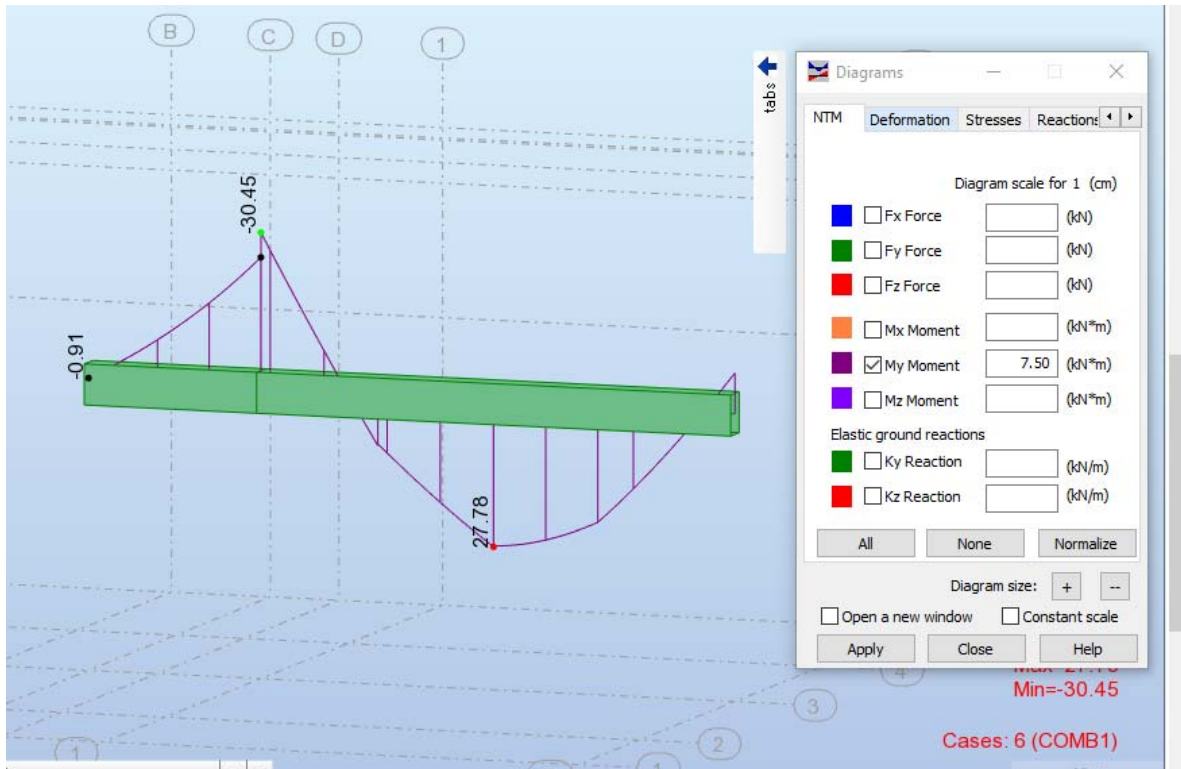

Figure 12. Rezultatet e momenteve maksimale sipas COMB 1

Rezultatet e forcave prerese jane si me poshte nga tre kombinimet dhe maksimalja eshte per kombinimin 1 te ngarkesave:

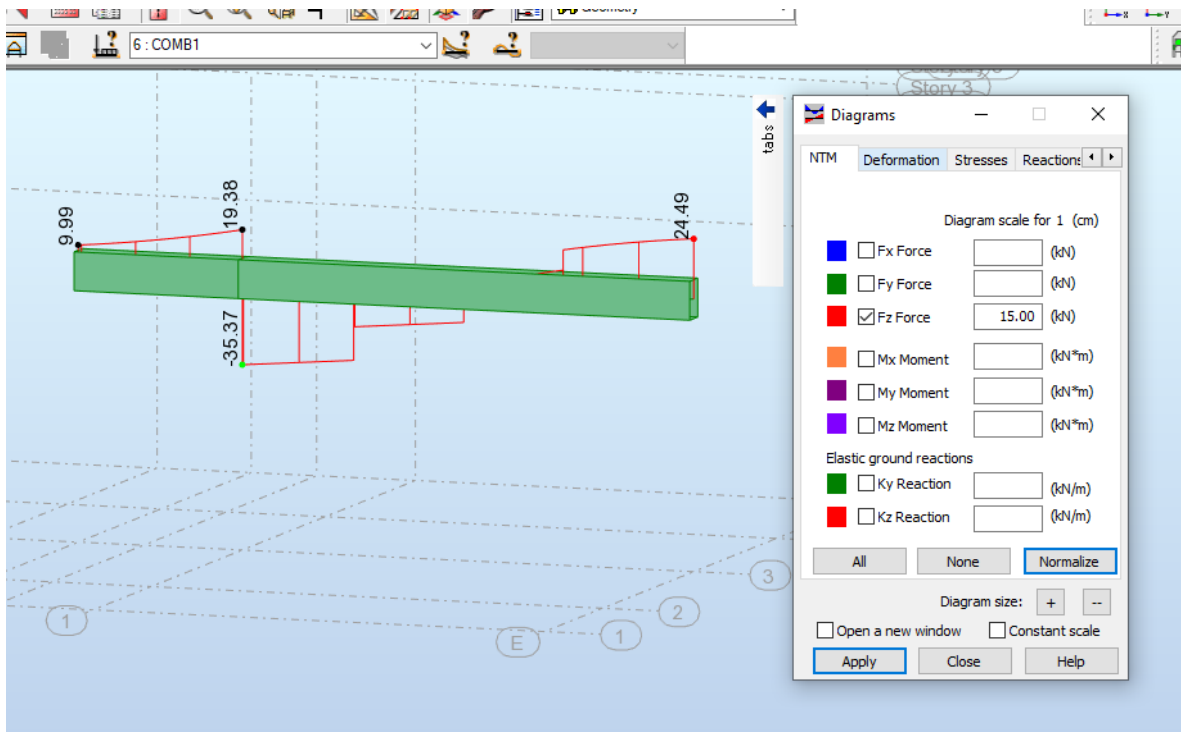

Figure 13. Rezultatet e forcave prerese maksimale sipas COMB 1

Sipas analizes me siper traret jane armuar bazuar mbi kerkesat e minimumit konstruktiv te EC2 dhe EC8 si ne figuren me poshte:

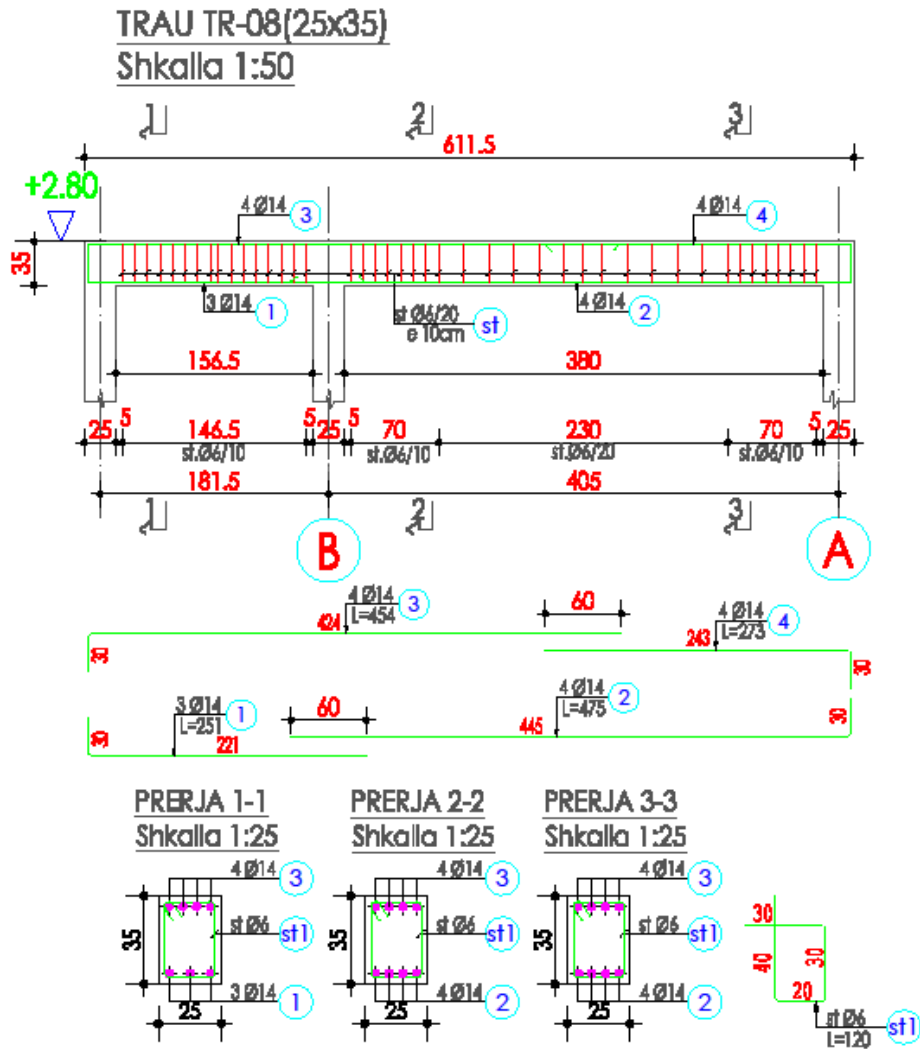

Figure 14. Armimi i traut Tr-08

- ❖ Per te realizuar kontrollin e kollonave te objektit eshte marre ne analize kollona si me poshte dhe eshte paraqitur raporti i plote i llogaritjeve per kete kollone.

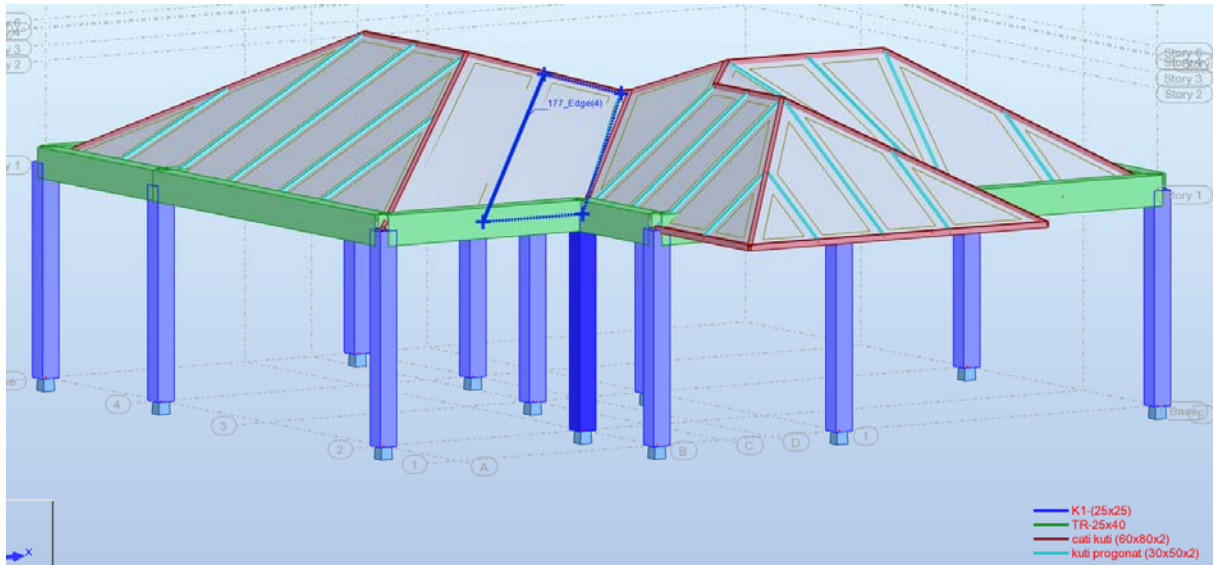

Figure 15. Paraqitja e kollones se marre ne analize

- ❖ Me poshte paraqitet analiza e kollones e nxjerre nga programi:

ot Structural Analysis Professional 2018 - Project: Structure 2+1 BETON ARME-perfundimtare pa strehe (Structure 2+1 BI)

analysis Results Reinforcement Tools Add-Ins Window Help Community

Structure Column-View Column-Results Column-Reinforcement Column-note

1 Level:

- Name: 0.00 (m)
- Reference level: 0.00 (m)
- Concrete creep coefficient: $\phi_p = 3.26$
- Cement class: N
- Environment class: X0
- Structure class: S1

2 Column: Column9 Number: 1

2.1 Material properties:

- Concrete: C20/25 $f_{ck} = 20.00$ (MPa)
- Unit weight: 2501.36 (kg/m³)
- Aggregate size: 20.0 (mm)
- Longitudinal reinforcement: B500C $f_{yk} = 500.00$ (MPa)
- Ductility class: C
- Transversal reinforcement: B500C $f_{yk} = 500.00$ (MPa)

2.2 Geometry:

- 2.2.1 Rectangular: 25.0 x 25.0 (cm)
- 2.2.2 Height: L = 3.00 (m)
- 2.2.3 Slab thickness: = 0.00 (m)
- 2.2.4 Beam height: = 0.40 (m)
- 2.2.5 Cover: = 4.0 (cm)

2.3 Calculation options:

- Calculations according to: EN 1992-1-1:2004 AC:2008
- Seismic dispositions: No requirements
- Precast column: no
- Pre-design: no
- Slenderness taken into account: yes
- Compression: with bending
- Ties: to slab
- Fire resistance class: No requirements

2.4 Loads:

Case	Nature	Group	γ_f	N (kN)	My(s) (kN*m)	My(i) (kN*m)	Mz(s) (kN*m)	Mz(i) (kN*m)
COMB1	design(Structural)	9	1.00	24.82	3.89	-4.69	-2.13	2.43
COMB2	design(Structural)	9	1.00	25.95	14.25	-10.82	-5.33	-3.00
COMB3	design(Structural)	9	1.00	27.86	7.20	-3.12	-9.96	-7.96
COMB4	design(Structural)	9	1.00	22.15	1.10	-1.51	-1.45	1.63
COMB5	design(Structural)	9	1.00	19.38	3.45	-4.43	-1.14	1.36
COMB6	design(Structural)	9	1.00	22.05	1.67	-2.28	-2.51	2.77
COMB7	design(Structural)	9	1.00	19.86	2.31	-2.98	-0.75	0.79

γ_f - load factor

2.5 Calculation results:

Safety factors Rd/Ed = 1.80 > 1.0

2.5.1 ULS/SLS Analysis

Design combination: COMB2 (A)

Combination type: ULS

Internal forces:

Nsd = 25.95 (kN) Msdy = 14.25 (kN*m) Msdz = -5.33 (kN*m)

Design forces:

Upper node
N = 25.95 (kN) N*etotz = 14.43 (kN*m) N*etoty = -5.33 (kN*m)

Eccentricity:

	ez (My/N)	ey (Mz/N)
Static	eEd: 54.9 (cm)	-20.5 (cm)
Imperfection	eI: 0.7 (cm)	0.0 (cm)
Initial	e0: 55.6 (cm)	-20.5 (cm)
Minimal	eImin: 2.0 (cm)	2.0 (cm)
Total	etot: 55.6 (cm)	-20.5 (cm)

2.5.1.1 Detailed analysis-Direction Y:

2.5.1.1.1 Slenderness analysis

Non-sway structure

L (m)	Lo (m)	λ	λ_{lim}	
2.80	2.80	38.80	216.33	Short column

2.5.1.1.2 Buckling analysis

MA = 14.25 (kN*m) MB = -10.82 (kN*m)

Case: Cross-section at the column end (Upper node), Slenderness not taken into account

M0 = 14.25 (kN*m)

ea = 61*lo/2 = 0.7 (cm)

$\theta_1 = 6\alpha \cdot \alpha_{11} \cdot \alpha_m = 0.01$

$\theta_0 = 0.01$

$\alpha_{zh} = 1.00$

$\alpha_{zm} = (0.5(1+1/m))^0.5 = 1.00$

m = 1.00

Ma = N*ea = 0.18 (kN*m)

MEdmin = 0.52 (kN*m)

MOEd = max(MEdmin, M0 + Ma) = 14.43 (kN*m)

2.5.1.2 Detailed analysis-Direction Z:

MA = -5.33 (kN*m) MB = -3.00 (kN*m)

Case: Cross-section at the column end (Upper node), Slenderness not taken into account

M0 = -5.33 (kN*m)

ea = 0.0 (cm)

Ma = N*ea = 0.00 (kN*m)

MEdmin = 0.52 (kN*m)

MOEd = max(MEdmin, M0 + Ma) = -5.33 (kN*m)

2.5.2 Reinforcement:

Real (provided) area $A_{sr} = 6.16 \text{ (cm}^2\text{)}$
 Ratio: $\rho = 0.99 \%$

2.6 Reinforcement:

Main bars (B500C):

- 4 $\phi 14 = 2.96 \text{ (m)}$

Transversal reinforcement: (B500C):

stirrups: 14 $\phi 6$ $l = 0.78 \text{ (m)}$

Material survey:

- Concrete volume = 0.16 (m3)
- Formwork = 2.60 (m2)
- Steel B500C
 - Total weight = 16.73 (kG)
 - Density = 102.95 (kG/m3)
 - Average diameter = 10.2 (mm)
 - Reinforcement survey:

Diameter	Length (m)	Weight (kG)	Number (No.)	Total weight (kG)
6	0.78	0.17	14	2.42
14	2.96	3.58	4	14.31

Sipas relacionit te mesiperme te marre nga programi rezulton se % e armimit te nevojshem te kollones na del 0.99 %, e cila eshte me e vogel se minimumi i lejuar nga kodi per armaturen gjatesore te kollones.

Kollona, bazuar ne rregullat e EC2 do te armohet me minimumin e shufres $\phi 14$, numri I shufrave per faqe do te jete jo me pak se 3shufra dhe distance midis shufrave jo me e madhe se 20cm.

Bazuar ne minimumin konstruktiv per kolonat e objektit 2+1 eshte dhene armimi si me poshte:



Figura 16. Armimi i kolones b/a(25x25)

Me poshte po japim disa skema dhe rezultate te marra nga llogaritjet:

EN 1993-1:2005/A1:2014 - Member Verification (SLS ; UL							
Results		Messages					
Member		Section	Material	Lay	Laz	Ratio	Case
6 Beam_6	OK	kuti progonat (30x50x2)	S 275	126.54	189.88	0.12	6 COMB1
114 Beam_114	OK	kuti progonat (30x50x2)	S 275	122.72	184.15	0.22	6 COMB1
133 Beam_133	OK	kuti progonat (30x50x2)	S 275	90.06	135.14	0.24	6 COMB1
90 Beam_90	OK	cati kuti (60x80x2)	S 275	82.18	102.66	0.24	6 COMB1
75 Beam_75	OK	cati kuti (60x80x2)	S 275	148.08	184.98	0.28	6 COMB1
80 Beam_80	OK	cati kuti (60x80x2)	S 275	129.39	161.62	0.29	6 COMB1
81 Beam_81	OK	cati kuti (60x80x2)	S 275	129.28	161.49	0.31	6 COMB1
126 Beam_126	OK	kuti progonat (30x50x2)	S 275	77.77	116.70	0.46	6 COMB1
61 Beam_61	OK	cati kuti (60x80x2)	S 275	67.93	84.85	0.50	6 COMB1
138 Beam_138	OK	kuti progonat (30x50x2)	S 275	164.03	246.14	0.51	6 COMB1
131 Beam_131	OK	kuti progonat (30x50x2)	S 275	100.04	150.12	0.56	6 COMB1
101 Beam_101	OK	cati kuti (60x80x2)	S 275	115.44	144.21	0.59	6 COMB1
93 Beam_93	OK	cati kuti (60x80x2)	S 275	121.89	152.26	0.63	6 COMB1
55 Beam_55	OK	cati kuti (60x80x2)	S 275	81.44	101.73	0.73	6 COMB1
77 Beam_77	OK	cati kuti (60x80x2)	S 275	147.85	184.68	0.73	6 COMB1
117 Beam_117	OK	kuti progonat (30x50x2)	S 275	107.89	161.89	0.75	6 COMB1
59 Beam_59	OK	cati kuti (60x80x2)	S 275	4.76	5.95	0.75	6 COMB1
110 Beam_110	OK	kuti progonat (30x50x2)	S 275	71.02	106.57	0.80	6 COMB1
136 Beam_136	OK	kuti progonat (30x50x2)	S 275	90.06	135.14	0.89	6 COMB1
130 Beam_130	OK	kuti progonat (30x50x2)	S 275	100.04	150.12	0.91	6 COMB1
103 Beam_103	OK	kuti progonat (30x50x2)	S 275	176.12	264.27	0.95	6 COMB1

Figura 17. Rezultatet e elementeve nga programi

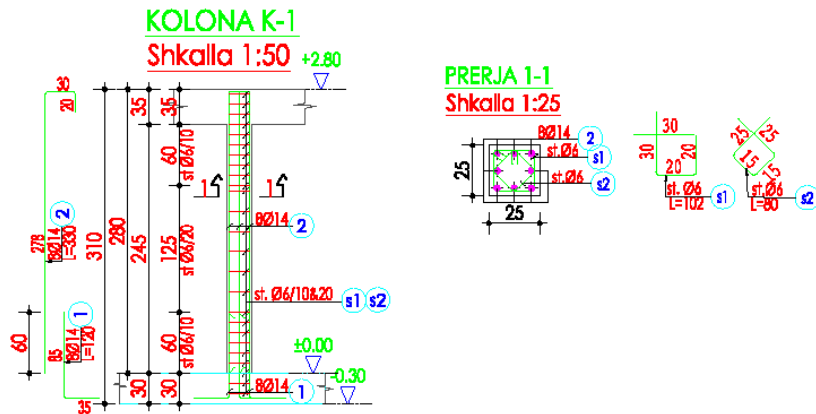
Me poshte do te te bashkangjirim edhe vizatimet nga projekti :



Figura 18. Plani i piketimit te pllakes se themelit



Figura 19. Plani i piketimit te trareve kryesore dhe sekondare per mbulimin

3. Modeli per vilen 3+1

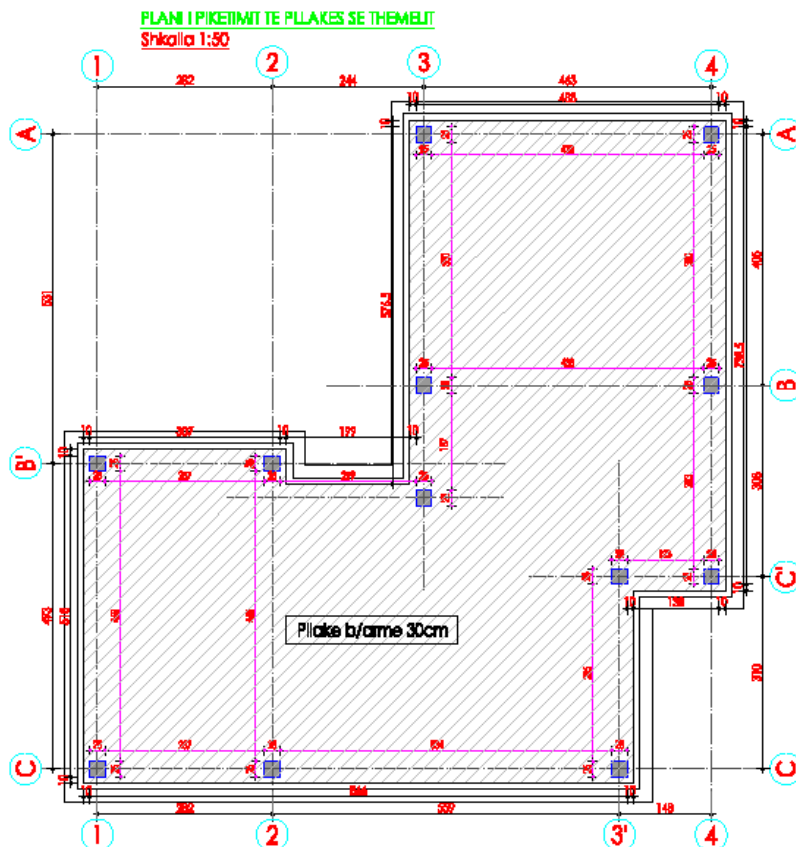

Figura 1. Modeli ne 3D

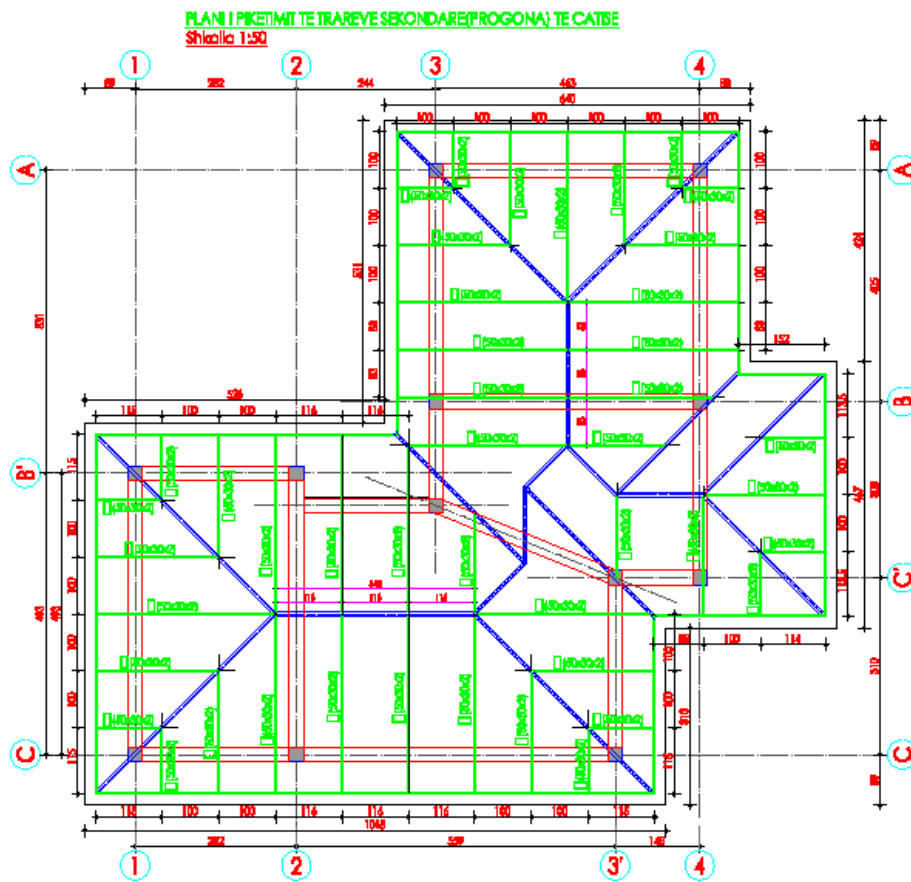

Figura 2. Ngarkesa e perhershme G

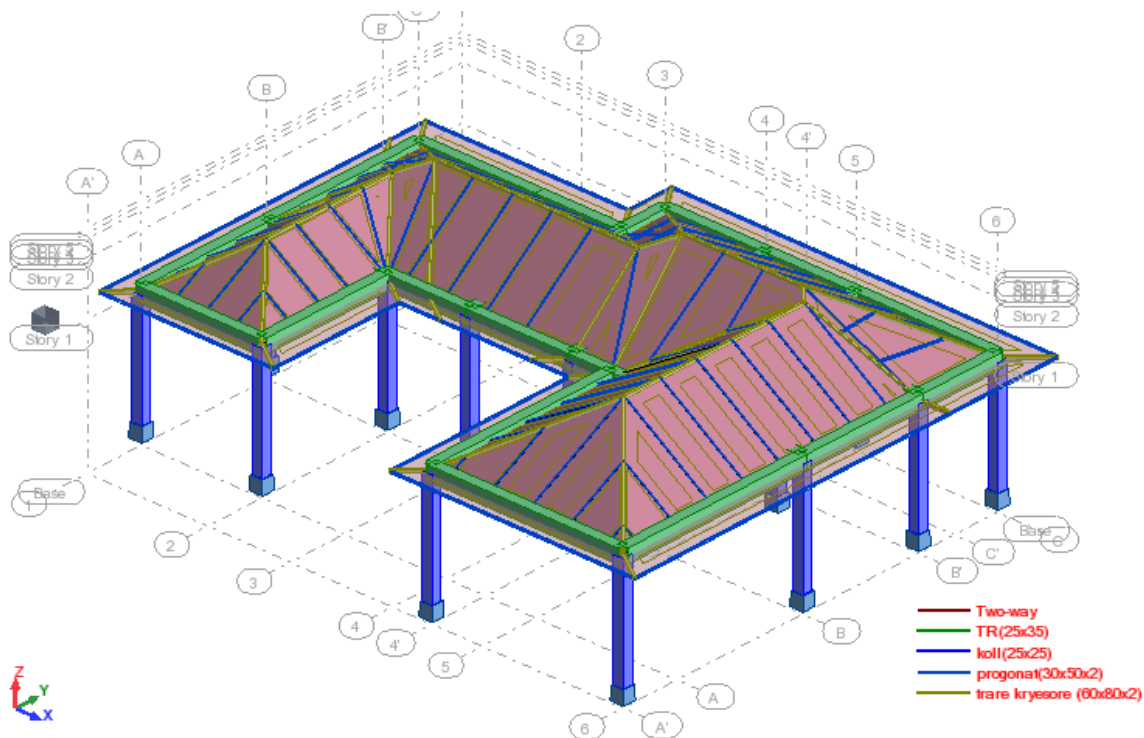

Figura 3. Ngarkesa e perkohshme P

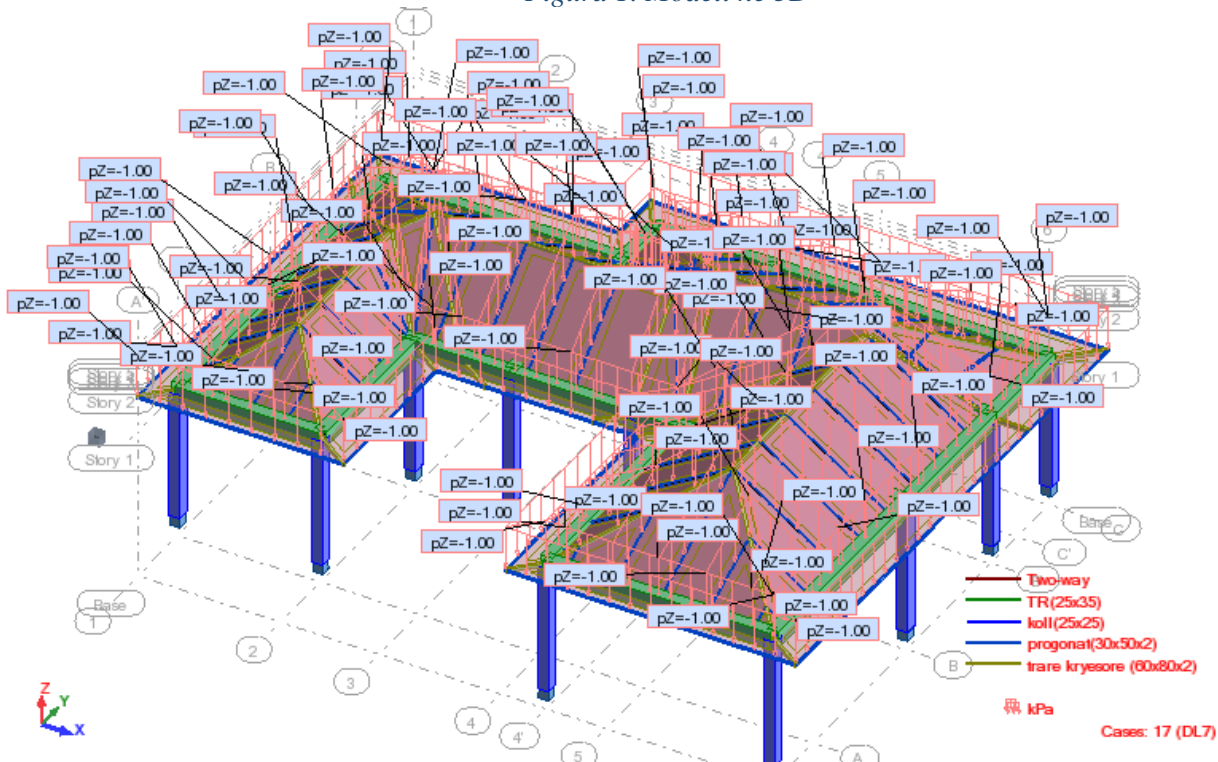

Figura 4. Ngarkesa e eres sipas drejtimet X me shpejtesi 30m/s

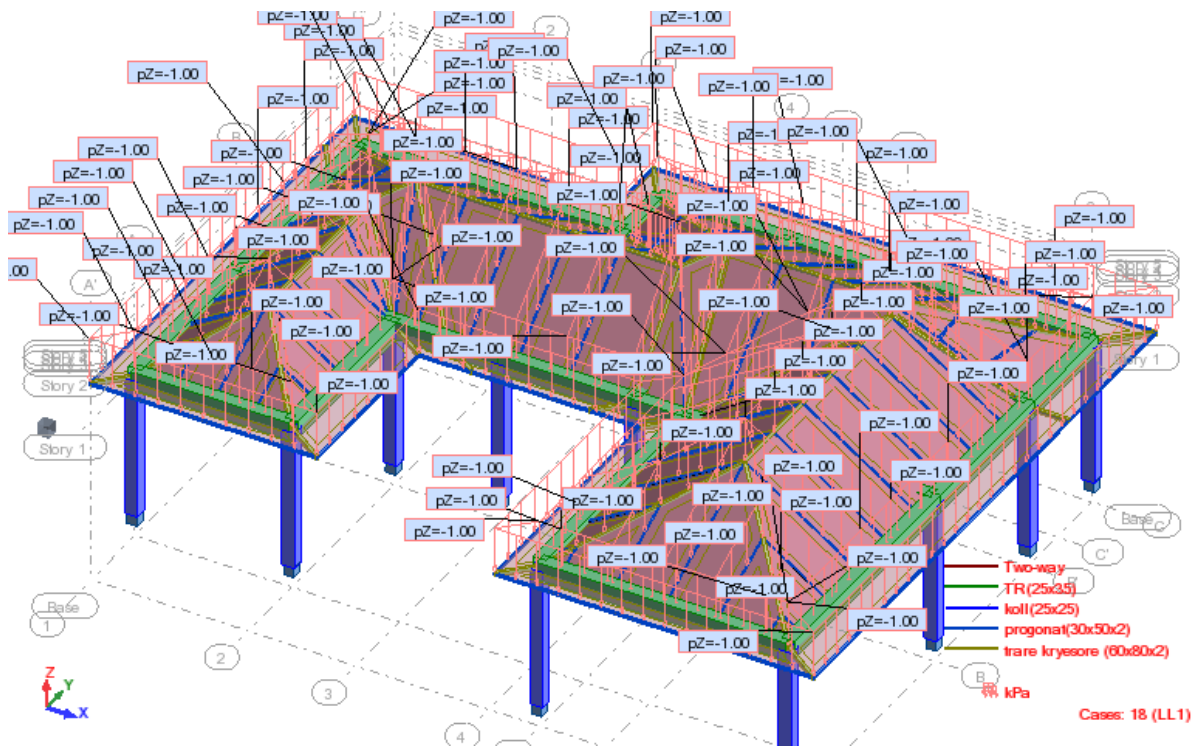

Figura 5. Ngarkesa e eres sipas drejtimet Y me shpejtesi 30m/s

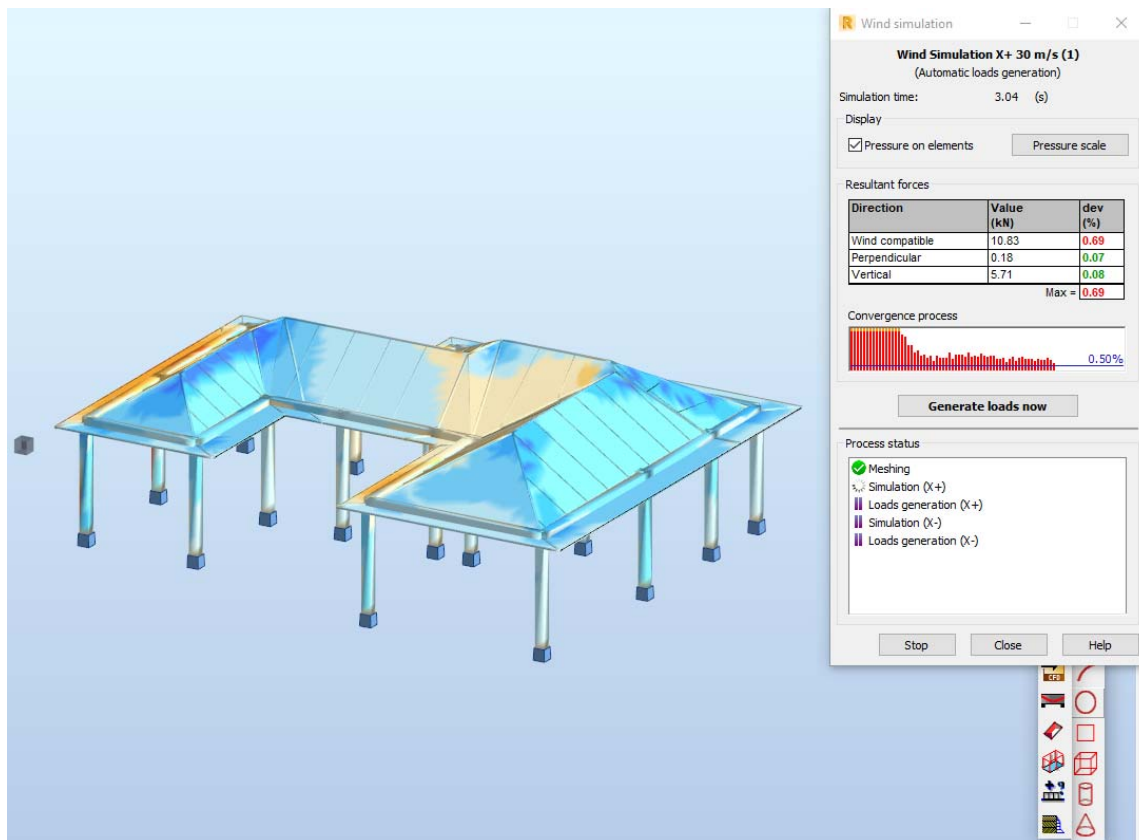

Figura 6. Ngarkesa e sizmikes ag,moduli i sjelljes dhe kategoria e truallit

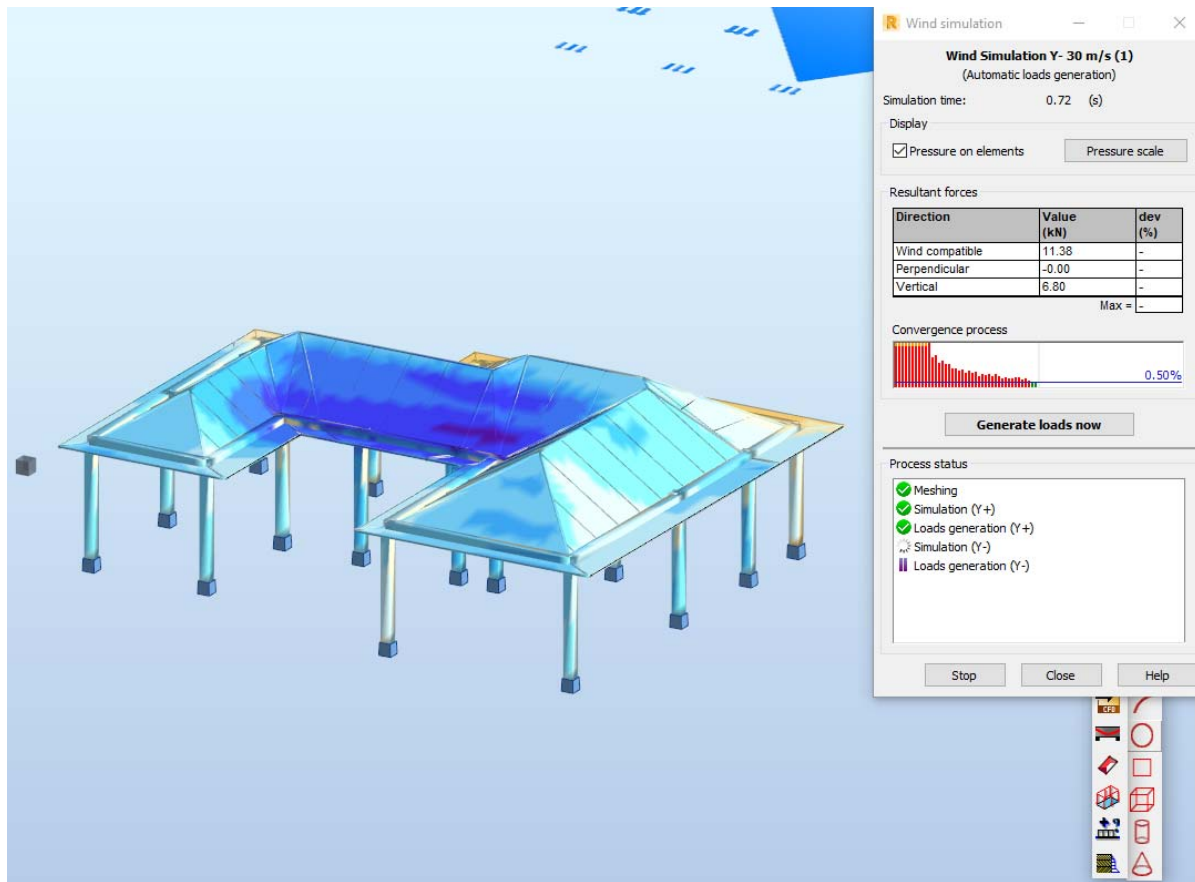

Figura 7. Rezultatet e drifteve nga programi

Perioda baze per seksionin e pare eshte **0.17sek** qe e fut godinen ne struktura mesatarisht te shtangeta deri pak fleksibel. Kjo periode eshte larg perodes vetiake te truallit cka shmang fenomenin e rezonances. Vlera e perodes eshte e perafert me ate qe rekomandon Eurokodi 8 per kete kategori strukturash. Sic shihet nga tabela, struktura nuk paraqet problematike per sa i perket fenomenit te perdredhjes. Dy format e para te lekundjes jane levizje translative.

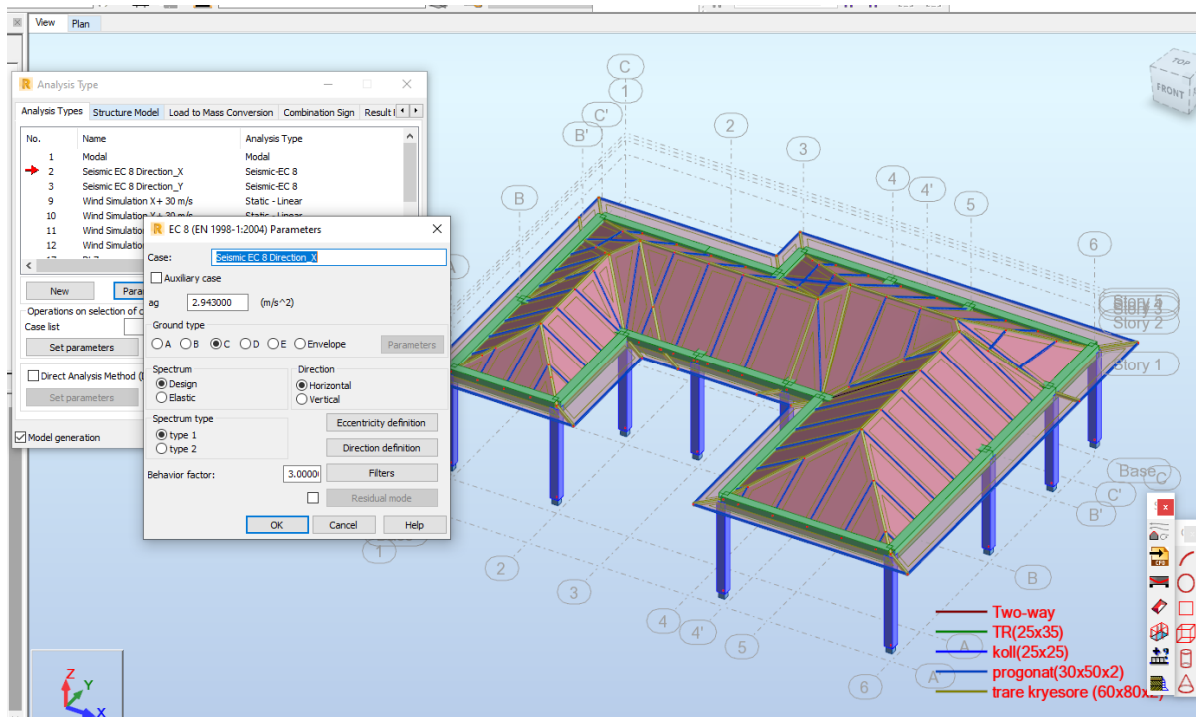
Case/Mode	Frequency (Hz)	Period (sec)	Rel.mas.UX (%)	Rel.mas.UY (%)	Rel.mas.UZ (%)	Cur.mas.UX (%)	Cur.mas.UY (%)	Cur.mas.UZ (%)	Total mass UX (kg)	Total mass UY (kg)	Total mass UZ (kg)
1/ 1	5.82	0.17	0.20	5.09	0.00	0.20	5.09	0.00	43241.81	43241.81	22944.09
1/ 2	6.75	0.15	63.02	19.34	0.00	62.81	14.25	0.00	43241.81	43241.81	22944.09
1/ 3	6.81	0.15	80.90	84.50	0.00	17.88	65.17	0.00	43241.81	43241.81	22944.09
1/ 4	7.85	0.13	83.58	95.87	0.00	2.68	11.36	0.00	43241.81	43241.81	22944.09
1/ 5	8.28	0.12	96.13	95.89	0.00	12.55	0.02	0.00	43241.81	43241.81	22944.09
1/ 6	9.20	0.11	97.13	98.00	0.00	1.00	2.11	0.00	43241.81	43241.81	22944.09
1/ 7	9.61	0.10	97.81	98.66	0.00	0.68	0.66	0.00	43241.81	43241.81	22944.09
1/ 8	10.98	0.09	98.77	98.68	0.01	0.95	0.01	0.00	43241.81	43241.81	22944.09
1/ 9	12.15	0.08	99.20	99.11	0.01	0.43	0.44	0.00	43241.81	43241.81	22944.09
1/ 10	13.31	0.08	99.23	99.36	0.02	0.03	0.25	0.01	43241.81	43241.81	22944.09

Figura 8. Rezultatet e perodes nga programi

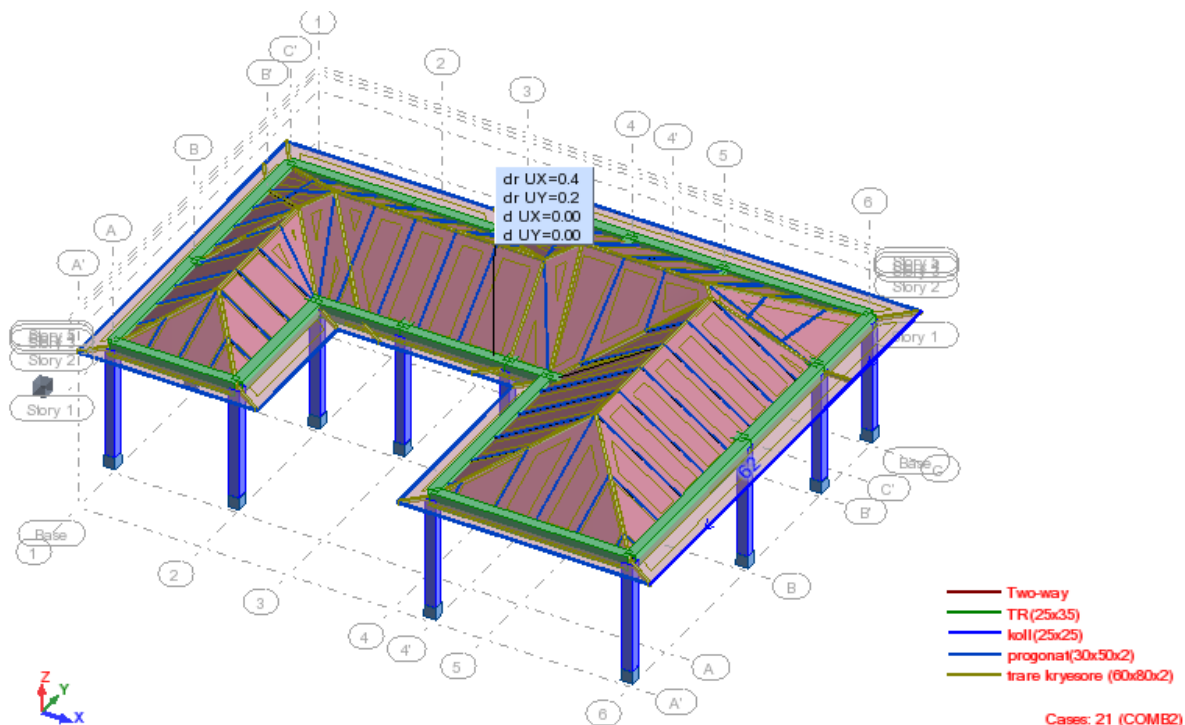
Per sa i perket drifteve qe ka struktura shikojme qe ato jane brenda vlerave qe lejon Eurokodi 8. Per rastin e kontrollit sipas termetit te projektimit duhet qe drifti maksimal i reduktuar me koeficientin ν te jete me i vogel se 0.5 % e lartesis se katit. Nga tabelat e drifteve shihet qe drifti maksimal eshte 0.4 cm.

$$v_{qd_r} < 0.005 \cdot 280 = 1.4 \text{ cm}$$

$$0,5 \cdot 0.4 < 0,005 \cdot 280 = 1.4 \text{ cm}$$

Pra sic shihet kontrolli per limitimin e drifteve eshte i siguruar.

Case/Story	UX (cm)	UY (cm)	dr UX (cm)	dr UY (cm)	d UX	d UY	Max UX (cm)	Max UY (cm)	Min UX (cm)	Min UY (cm)
21 (C) (CQC)	0.4	0.2	0.4	0.2	0.00	0.00	0.8	0.5	0.3	0.1
21 (C) (CQC)	0.0	0.0	N/A	N/A	N/A	N/A	N/A	N/A	N/A	N/A
21 (C) (CQC)	0.0	0.0	N/A	N/A	N/A	N/A	N/A	N/A	N/A	N/A
21 (C) (CQC)	0.0	0.0	N/A	N/A	N/A	N/A	N/A	N/A	N/A	N/A
21 (C) (CQC)	0.0	0.0	N/A	N/A	N/A	N/A	N/A	N/A	N/A	N/A

Figura 9. Rezultatet e drifteve nga programi

Edhe zhvendosjet maksimale elastoplastike qe rezultojne nga llogaritjet dhe perkatesisht $U_x = 0.8 \text{ cm}$, $U_y = 1.4 \text{ cm}$, $U_z = 0.7 \text{ cm}$ jane me te vogla se sa limitet qe percakton Eurokodi 8.

	UX (cm)	UY (cm)	UZ (cm)	RX (Rad)	RY (Rad)	RZ (Rad)
MAX	0.8	1.4	0.7	0.036	0.042	0.013
Node	121	121	129	240	65	119
Case	22 (C) (CQC)	22 (C) (CQC)	22 (C) (CQC)	22 (C) (CQC)	22 (C) (CQC)	22 (C) (CQC)
MIN	0.0	0.0	-0.4	-0.033	-0.046	-0.000
Node	1	1	240	62	64	25
Case	22 (C) (CQC)	22 (C) (CQC)	22 (C) (CQC)	22 (C) (CQC)	22 (C) (CQC)	22 (C) (CQC)

Figura 10. Rezultatet e zhvendosjeve nga programi

KONTROLLI I KAPACITETIT TE ELEMENTEVE

Elementet kryesore te struktures si trare, kollona jane kontrolluar me vete per te analizuar me ne detaje menyren e punes se tyre. Nga programi marrim momentet dhe forcat prerese per traret dhe kollonat si me poshte:

- ❖ Per Traun Tr-03 merren vlerat maksimale per tre kombinimet e ngarkesave te momentit dhe forces prerese, per te bere llogaritjen e armatures se nevojshme.



Figura 11. Paraqitja e traut TR-03 te marre ne analize



Figura 12. Rezultatet maksimale te momenteve te traut sipas COMB 2

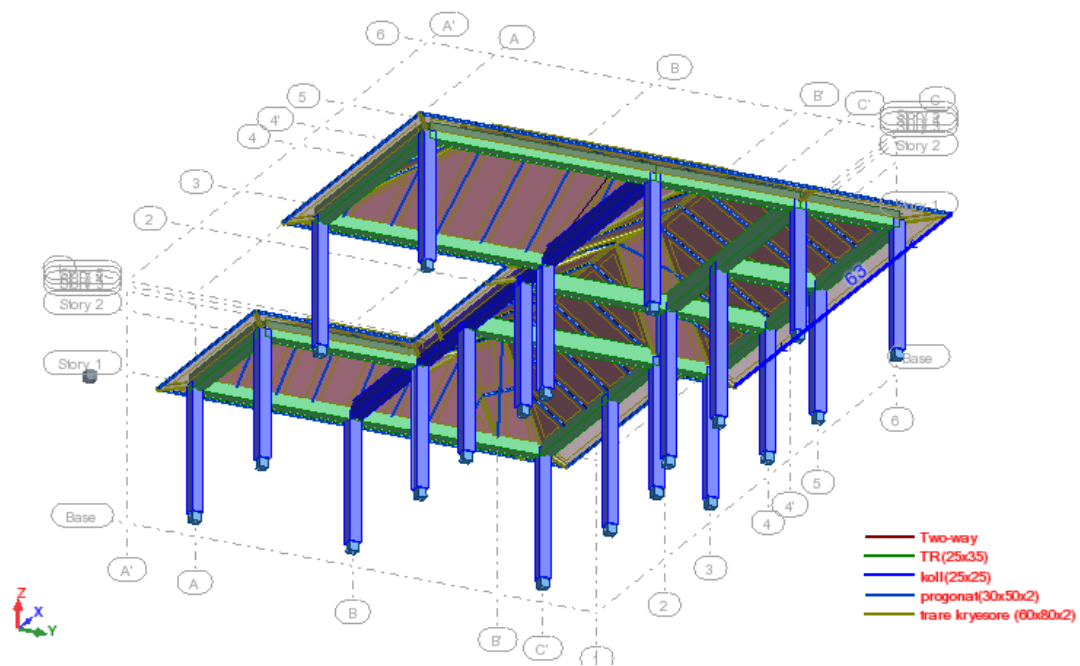

Figura 13. Rezultatet maksimale te F_z te traut sipas COMB 1

Sipas analizes me siper traret jane armuar bazuar mbi kerkesat e minimumit konstruktiv te EC2 dhe EC8 si ne figuren me poshte:

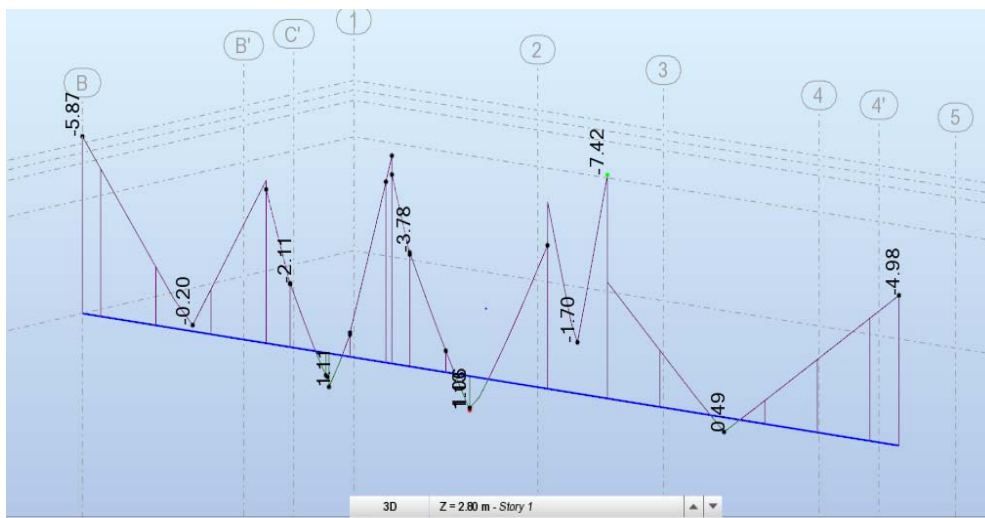

Figura 14. Armimi i traut TR-03(25x35)

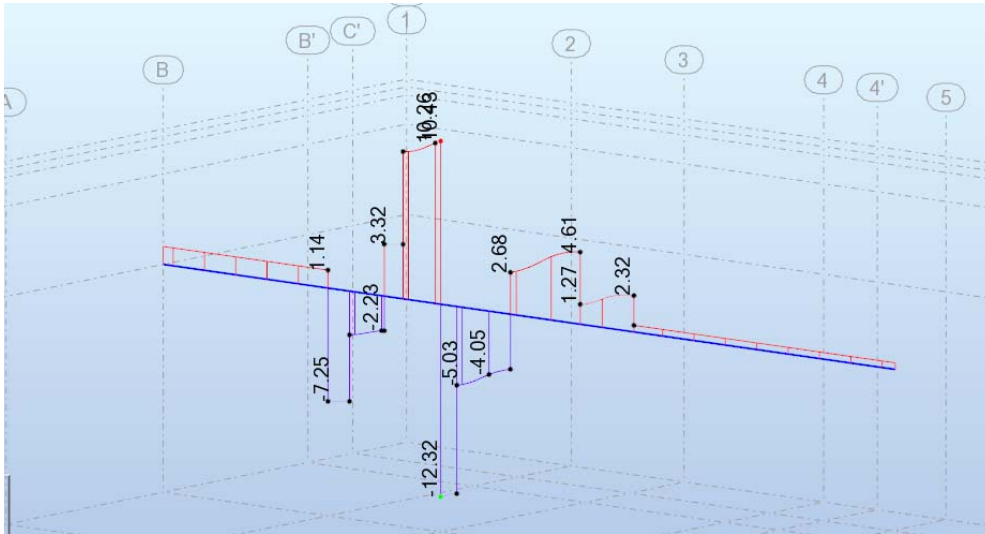
- ❖ Per te realizuar kontrollin e kolonave te objektit 3+1 eshte marre ne analize kollona si me poshte :

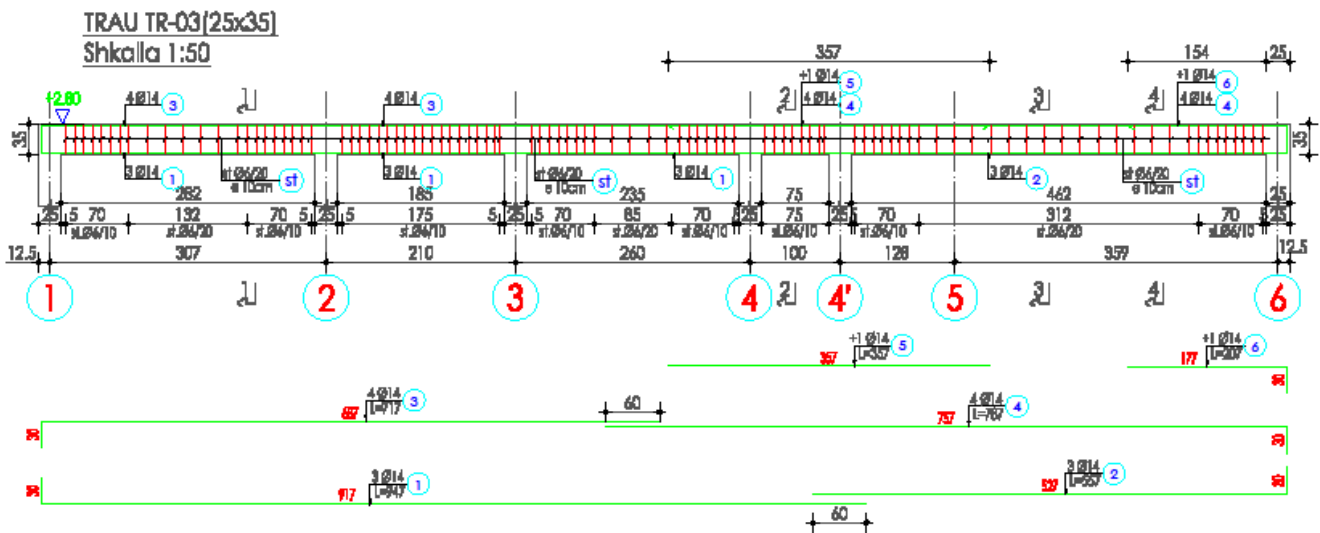
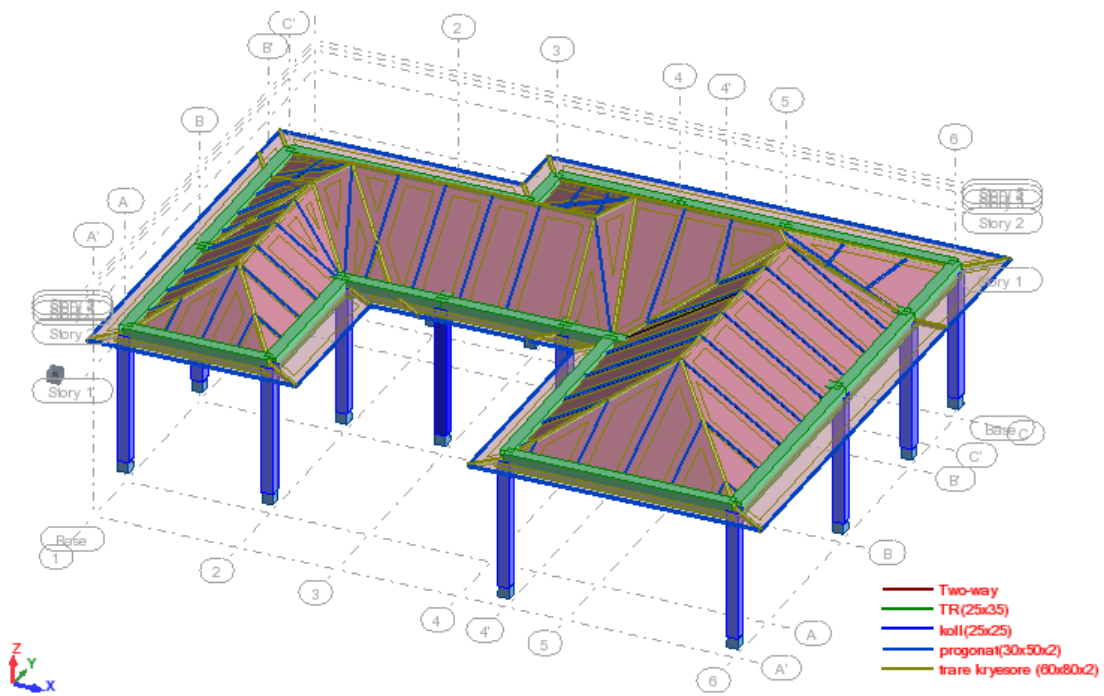

Figure 15. Paraqitja e kolones se marre ne analize

Me poshte paraqitet analiza e kolones e nxjerre nga programi:

- ❖ Sipas relacionit te nga programi rezulton se % e armimit te nevojshem te kollones eshte sa minimumi i lejuar nga kodi per armaturen gjatesore te kollones.
- ❖ Kollona, bazuar ne rregullat e EC2 do te armohet me minimumin e shufres Ø14, numri I shufrave per faqe do te jete jo me pak se 3shufra dhe distance midis shufrave jo me e madhe se 20cm.
- ❖ Bazuar ne minimumin konstruktiv per kolonat e objektit 3+1 eshte dhene armimi si me poshte:



Figura 16. Armimi i kolones b/a(25x25)

Me poshte po japim disa skema dhe rezultate te marra nga llogaritjet:

Member	Section	Material	Lay	Laz	Ratio	Case	Ratio(uy)	Case (uy)	Ratio(uz)	Case (uz)
241 Beam_241	progonat(30x50x2)	S 275	152.15	228.30	0.03	20 COMB1	0.00	17 DL7	0.01	17 DL7
72 Beam_72	trare kryesore (60x80x2)	S 275	79.04	98.73	0.09	20 COMB1	0.01	2 Seismic EC 8 Direc	0.01	3 Seismic EC 8 Direc
261 Beam_261	trare kryesore (60x80x2)	S 275	114.15	142.59	0.10	20 COMB1	0.01	2 Seismic EC 8 Direc	0.02	2 Seismic EC 8 Direc
71 Beam_71	trare kryesore (60x80x2)	S 275	84.04	104.98	0.10	20 COMB1	0.01	3 Seismic EC 8 Direc	0.01	17 DL7
254 Beam_254	progonat(30x50x2)	S 275	48.35	72.56	0.13	20 COMB1	0.00	3 Seismic EC 8 Direc	0.00	17 DL7
75 Beam_75	trare kryesore (60x80x2)	S 275	27.93	34.88	0.13	20 COMB1	0.00	17 DL7	0.01	17 DL7
256 Beam_256	progonat(30x50x2)	S 275	45.07	67.64	0.14	20 COMB1	0.01	2 Seismic EC 8 Direc	0.00	17 DL7
51 Beam_51	progonat(30x50x2)	S 275	54.02	81.05	0.15	20 COMB1	0.00	17 DL7	0.01	17 DL7
198 Beam_198	progonat(30x50x2)	S 275	26.83	40.26	0.16	20 COMB1	0.00	17 DL7	0.01	17 DL7
105 Beam_105	progonat(30x50x2)	S 275	28.93	43.42	0.17	20 COMB1	0.00	17 DL7	0.01	17 DL7
15 Beam_15	progonat(30x50x2)	S 275	54.02	81.05	0.17	20 COMB1	0.00	2 Seismic EC 8 Direc	0.01	17 DL7
76 Beam_76	trare kryesore (60x80x2)	S 275	106.72	133.31	0.17	20 COMB1	0.01	2 Seismic EC 8 Direc	0.01	17 DL7
255 Beam_255	progonat(30x50x2)	S 275	53.96	80.97	0.18	20 COMB1	0.00	17 DL7	0.01	17 DL7
151 Beam_151	trare kryesore (60x80x2)	S 275	81.98	102.41	0.18	20 COMB1	0.02	2 Seismic EC 8 Direc	0.03	17 DL7
214 Beam_214	trare kryesore (60x80x2)	S 275	28.91	43.38	0.18	20 COMB1	0.00	17 DL7	0.01	17 DL7
99 Beam_99	trare kryesore (60x80x2)	S 275	79.04	98.73	0.18	20 COMB1	0.01	17 DL7	0.02	17 DL7
104 Beam_104	progonat(30x50x2)	S 275	28.93	43.42	0.19	20 COMB1	0.00	17 DL7	0.01	17 DL7
88 Beam_88	trare kryesore (60x80x2)	S 275	127.59	159.38	0.22	20 COMB1	0.03	3 Seismic EC 8 Direc	0.05	17 DL7
89 Beam_89	trare kryesore (60x80x2)	S 275	122.41	152.91	0.24	20 COMB1	0.04	2 Seismic EC 8 Direc	0.04	17 DL7
263 Beam_263	progonat(30x50x2)	S 275	55.30	82.98	0.25	20 COMB1	0.03	3 Seismic EC 8 Direc	0.34	3 Seismic EC 8 Direc
260 Beam_260	progonat(30x50x2)	S 275	83.34	125.06	0.26	20 COMB1	0.01	17 DL7	0.03	17 DL7
167 Beam_167	trare kryesore (60x80x2)	S 275	84.04	104.98	0.26	20 COMB1	0.02	2 Seismic EC 8 Direc	0.04	17 DL7
233 Beam_233	progonat(30x50x2)	S 275	70.51	105.80	0.26	20 COMB1	0.00	2 Seismic EC 8 Direc	0.03	17 DL7
30 Beam_30	progonat(30x50x2)	S 275	53.92	80.92	0.26	20 COMB1	0.00	17 DL7	0.01	17 DL7
266 Beam_266	progonat(30x50x2)	S 275	96.09	144.18	0.27	20 COMB1	0.03	17 DL7	0.06	3 Seismic EC 8 Direc
259 Beam_259	progonat(30x50x2)	S 275	68.83	103.28	0.29	20 COMB1	0.02	17 DL7	0.04	2 Seismic EC 8 Direc
55 Beam_55	progonat(30x50x2)	S 275	107.85	161.83	0.29	20 COMB1	0.01	3 Seismic EC 8 Direc	0.07	17 DL7
54	progonat(30x50x2)	S 275	55.53	83.33	0.29	20 COMB1	0.00	17 DL7	0.01	17 DL7
238 Beam_238	trare kryesore (60x80x2)	S 275	135.71	169.52	0.30	20 COMB1	0.02	3 Seismic EC 8 Direc	0.04	3 Seismic EC 8 Direc
249 Beam_249	progonat(30x50x2)	S 275	107.31	161.02	0.30	20 COMB1	0.01	10 Wind Simulation	0.05	17 DL7
135 Beam_135	trare kryesore (60x80x2)	S 275	109.23	136.44	0.31	20 COMB1	0.01	17 DL7	0.04	17 DL7
77 Beam_77	trare kryesore (60x80x2)	S 275	168.61	210.62	0.31	20 COMB1	0.02	2 Seismic EC 8 Direc	0.03	17 DL7
79 Beam_79	trare kryesore (60x80x2)	S 275	29.14	36.40	0.33	20 COMB1	0.01	17 DL7	0.05	17 DL7
69 Beam_69	progonat(30x50x2)	S 275	236.85	355.40	0.37	20 COMB1	0.10	2 Seismic EC 8 Direc	0.05	17 DL7
20 Beam_20	progonat(30x50x2)	S 275	108.03	162.11	0.37	20 COMB1	0.00	17 DL7	0.10	17 DL7
166 Beam_166	trare kryesore (60x80x2)	S 275	104.77	130.87	0.38	20 COMB1	0.02	17 DL7	0.08	17 DL7
251 Beam_251	progonat(30x50x2)	S 275	96.71	145.11	0.39	20 COMB1	0.00	17 DL7	0.07	17 DL7
257 Beam_257	progonat(30x50x2)	S 275	56.28	84.45	0.39	20 COMB1	0.00	2 Seismic EC 8 Direc	0.03	17 DL7
176 Beam_176	trare kryesore (60x80x2)	S 275	25.83	32.26	0.40	20 COMB1	0.09	2 Seismic EC 8 Direc	0.05	17 DL7
80 Beam_80	trare kryesore (60x80x2)	S 275	99.47	124.26	0.41	20 COMB1	0.18	3 Seismic EC 8 Direc	0.31	3 Seismic EC 8 Direc
253 Beam_253	progonat(30x50x2)	S 275	96.71	145.11	0.41	20 COMB1	0.01	10 Wind Simulation	0.05	17 DL7
32 Beam_32	progonat(30x50x2)	S 275	107.85	161.83	0.42	20 COMB1	0.00	17 DL7	0.11	17 DL7
78 Beam_78	trare kryesore (60x80x2)	S 275	106.72	133.31	0.43	20 COMB1	0.04	3 Seismic EC 8 Direc	0.13	17 DL7
97 Beam_97	trare kryesore (60x80x2)	S 275	32.12	40.12	0.43	20 COMB1	0.20	2 Seismic EC 8 Direc	0.02	17 DL7
82 Beam_82	trare kryesore (60x80x2)	S 275	163.07	203.70	0.43	20 COMB1	0.10	3 Seismic EC 8 Direc	0.19	3 Seismic EC 8 Direc
134 Beam_134	trare kryesore (60x80x2)	S 275	85.67	107.01	0.45	20 COMB1	0.01	17 DL7	0.06	17 DL7
252 Beam_252	progonat(30x50x2)	S 275	96.71	145.11	0.45	20 COMB1	0.00	17 DL7	0.08	17 DL7
242 Beam_242	progonat(30x50x2)	S 275	149.44	224.24	0.45	20 COMB1	0.00	17 DL7	0.18	17 DL7

Figura 17. Rezultatet e elementeve nga programi

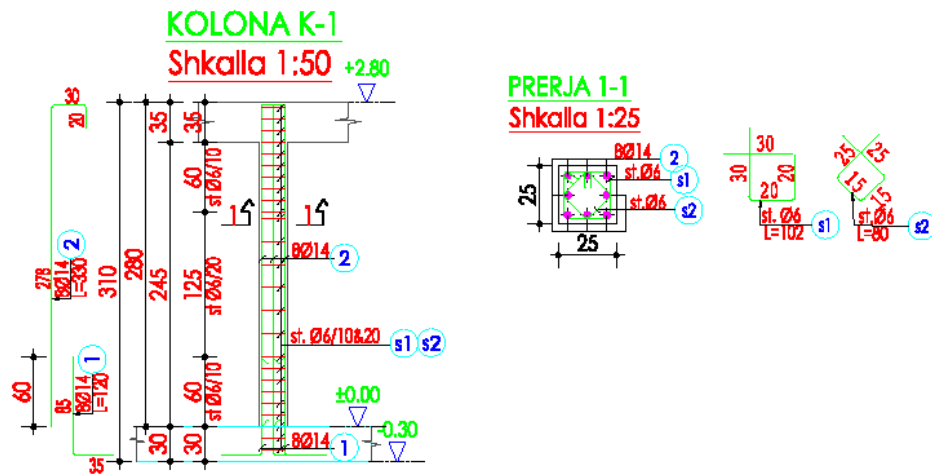
Me poshte do te te bashkangjism edhe vizatimet nga projekti :



Figura 18. Plani i piktimit te pllakes b/arme 30cm

Plani i piktimit te profileve te trareve kryesore sipas pjertesise se catise
Shkalla 1:75

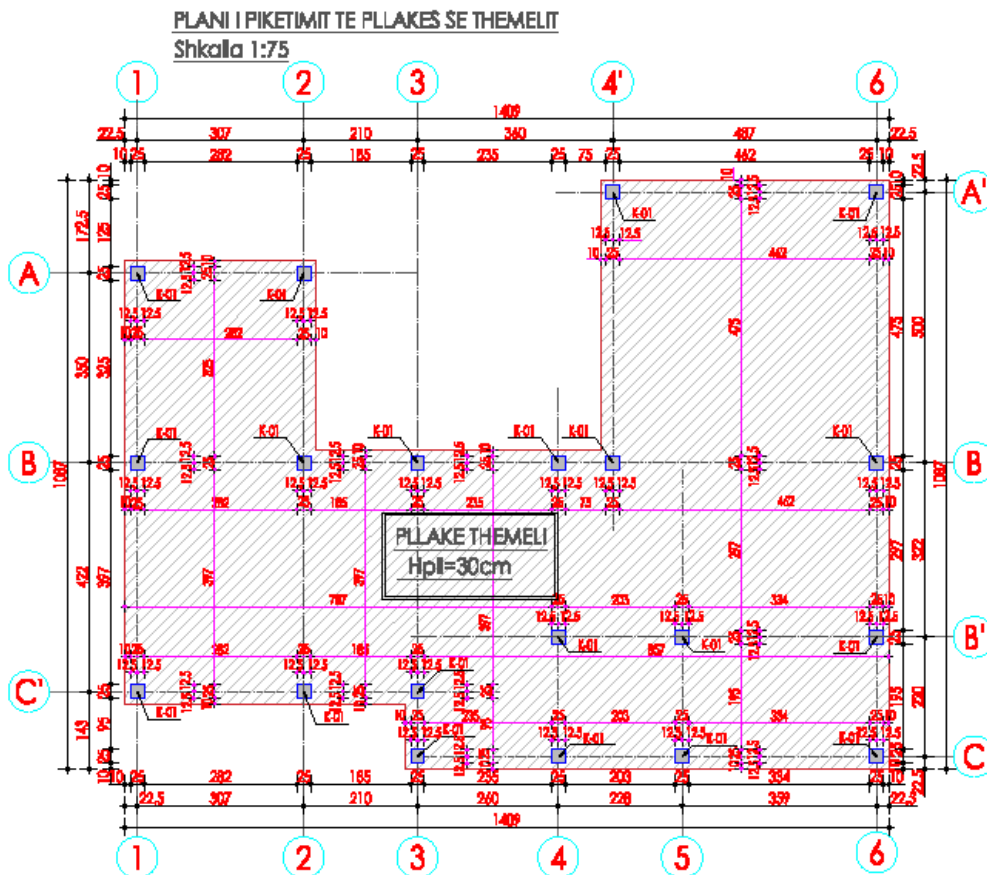

Figura 19. Plani i piktimit te profileve kryesore per mbulimin

Plani i piketimit te prigonave sipas pjerrtese se catise
Shkalla 1:75

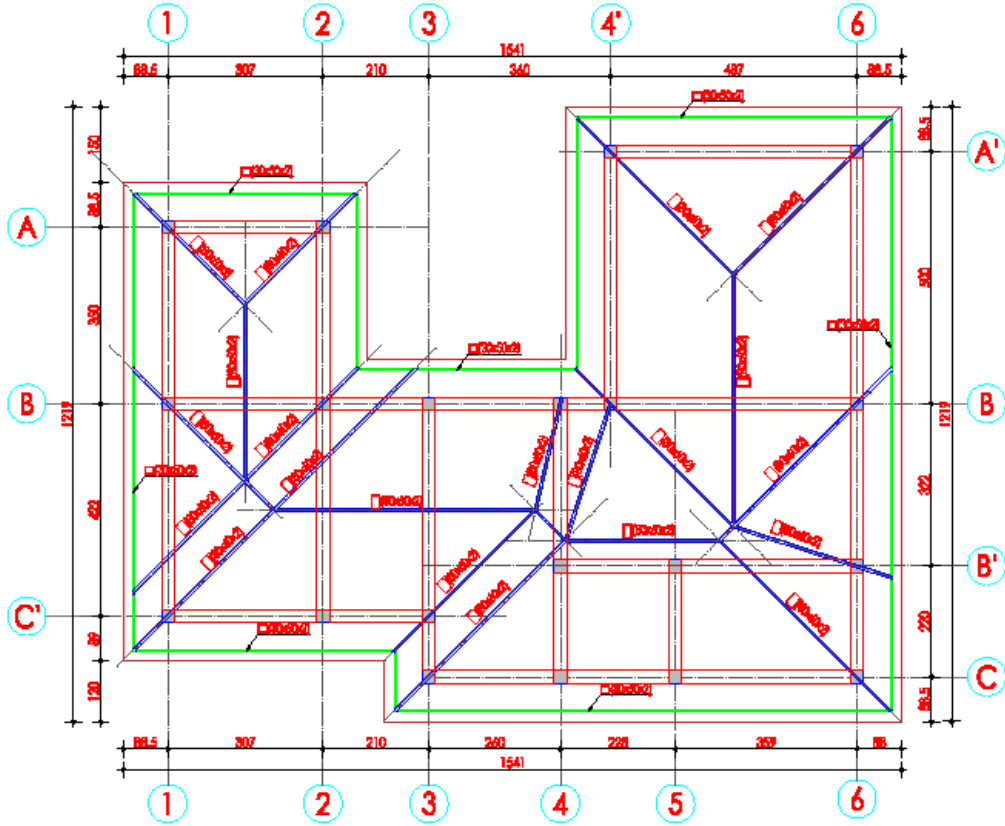
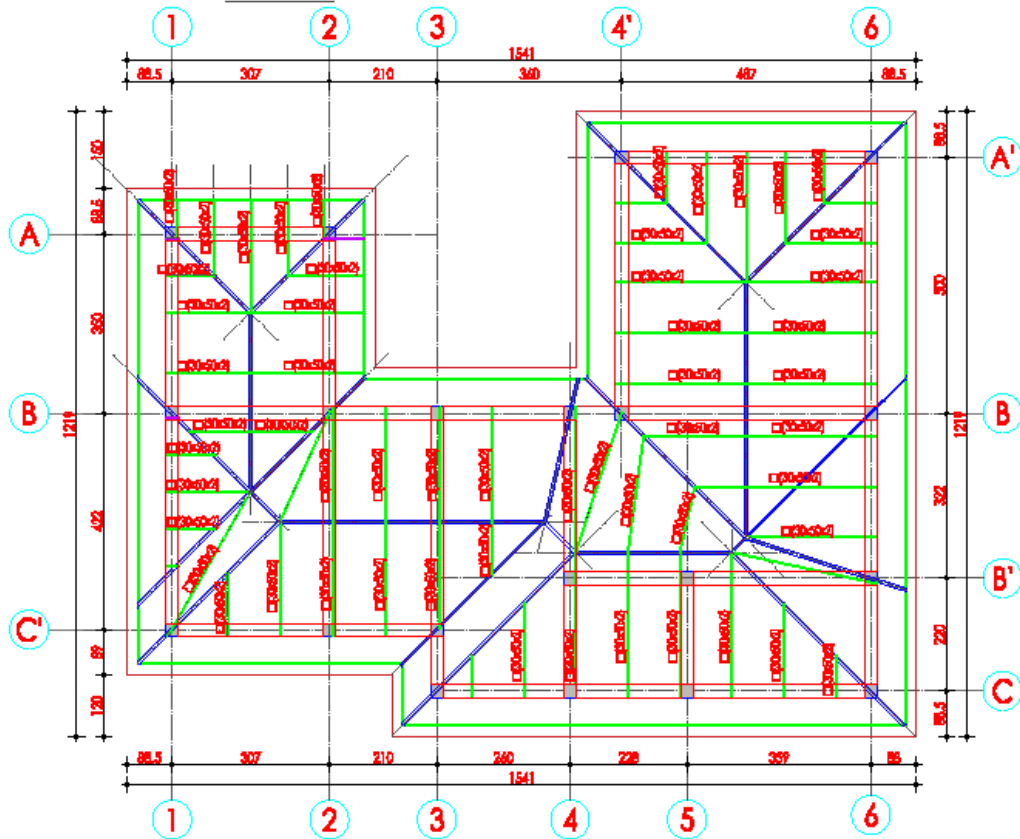

Figura 20. Plani i piketimit te profileve sekondare per mbulimin

KONKLUZIONE

Si perfundim bazuar ne llogaritjet si dhe duke analizuar modelin ne programin Robot Millenium arrijme ne keto konkluzione:

- Ngarkesat e marra ne studim jane ne konformitet me Eurokodet dhe kushtet teknike te projektimit ne fuqi,
- Ngarkesa sizmike eshte marre ne perputhje me Eurokodin 8,
- Perioda e lekundjeve te godines eshte brenda vlerave te rekomanduara nga Eurokodi 8
- Zhvendosjet dhe driftet e objekteve jane brenda vlerave te lejuara nga Eurokodi 8,
- Armimet e trareve, kolonave dhe themelit jane bere conform kerkesave te Eurokodit 2 dhe 8.